



BOOTH & Co.

ENGLAND

This instruction booklet covers model:

BC-AXB-SFSRK-CP
BC-AXB-SFSRK-BN

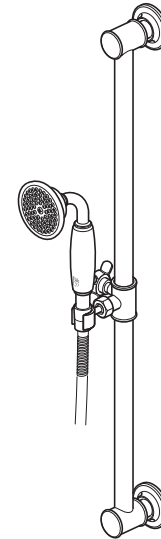

VADO
Wedmore Road, Cheddar,
Somerset, England BS27 3EB
tel 01934 744466
fax 01934 744345
www.vado.com
sales@vado.com

Version 1, 1-5-19

AXBRIDGE

BC-AXB-SFSRK-CP
BC-AXB-SFSRK-BN
INSTALLATION GUIDE

BOOTH & Co.

ENGLAND

Welcome

Thank you for choosing VADO

Our products can be found in some of the most prestigious hotel, commercial and residential developments across the world, therefore you can expect exceptional product quality and outstanding customer service.

This product has passed through stringent quality assurance processes coupled with demanding lifecycle mechanical testing to ensure it reaches the exacting standards that allow us to offer our premium 12 year guarantee.

We work to ensure our product designs are harmonious with all sanitaryware, so when you choose VADO, your choice of coordinating items is unlimited.

With VADO, you can really let your inspiration flow.

For any technical or operational queries please contact our experienced aftersales team on 01934 745163.

Important - please read

Please read these instructions carefully before starting installation and keep for future reference.

Remove all packaging and check the product for missing parts or damage before starting installation. Please take great care when installing this mixer not to damage its surface.

⚠ Warning! Please check for any hidden cables and pipes before drilling holes in the wall.

Note: The fixings supplied are for solid walls only. If you are fitting the accessory to a partition or wall of particularly soft substrate you will need specialist fixings.

Contents of Packaging

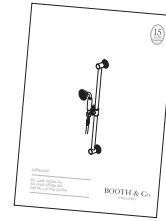

Installation guide &
User manual

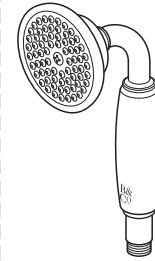

Handset

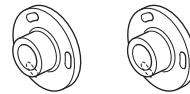

Wall brackets x 2



O-rings x 2

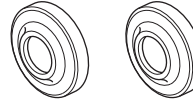

Covers x 2

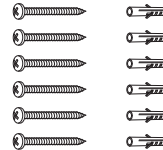

Screws x 6 Wall plugs x 6



Hex key

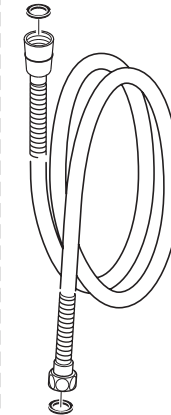

Shower hose
with 2 washers

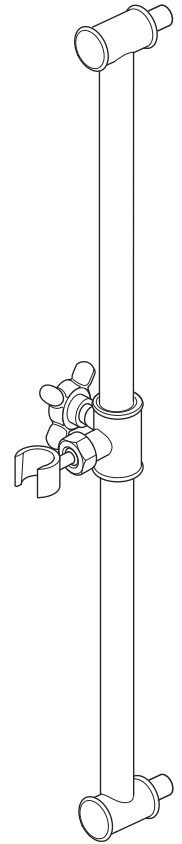

Riser rail

Dimensions

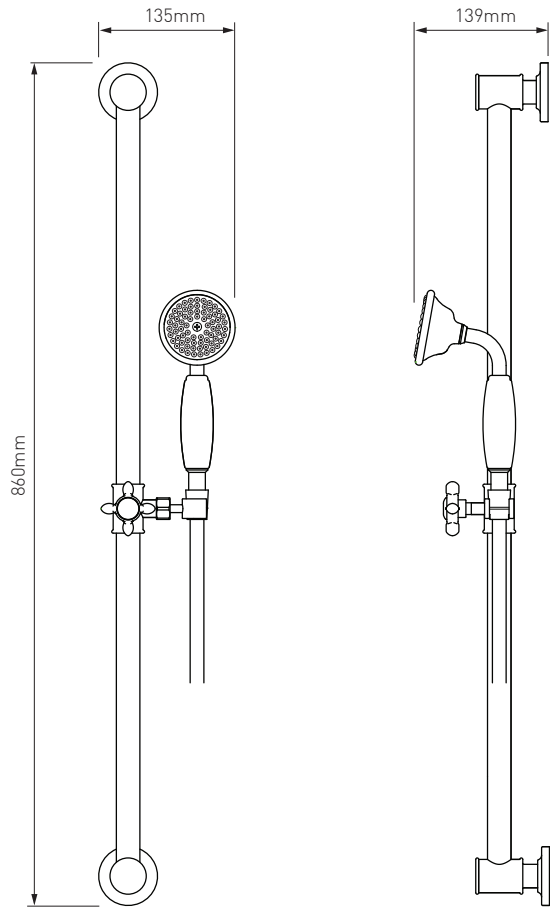

Installation - Quick guide

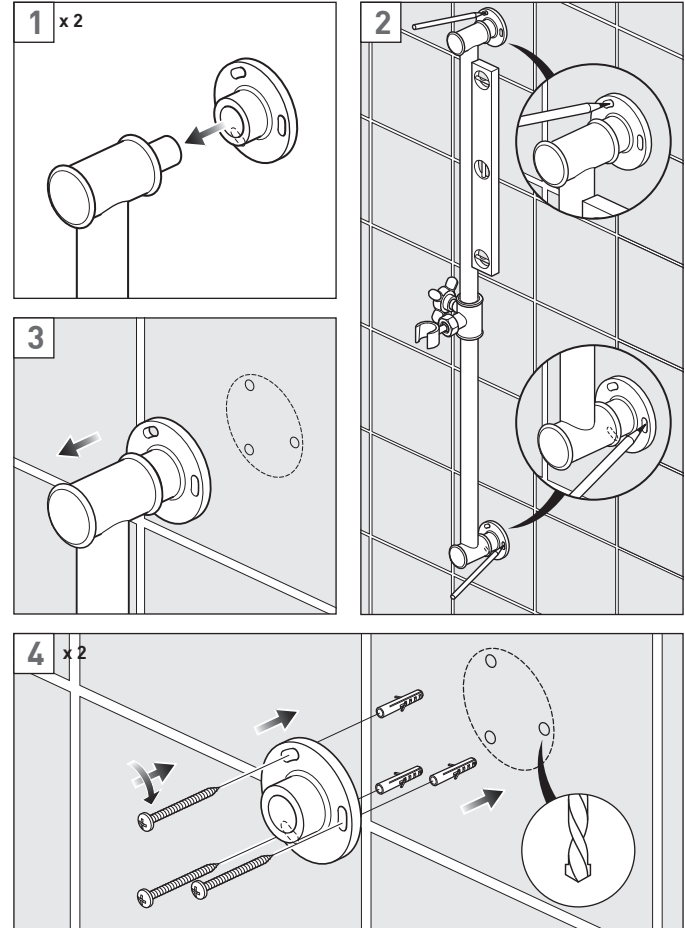

Installation - Quick guide

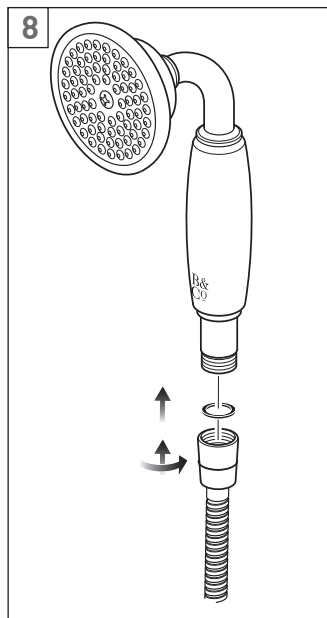
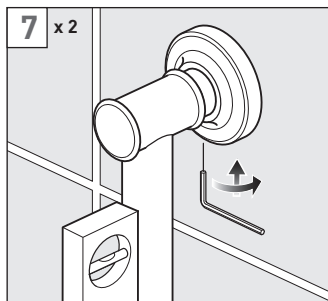
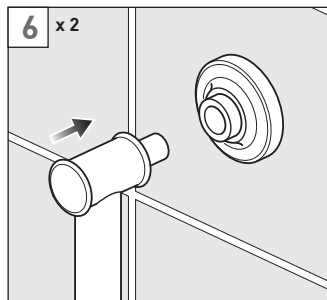
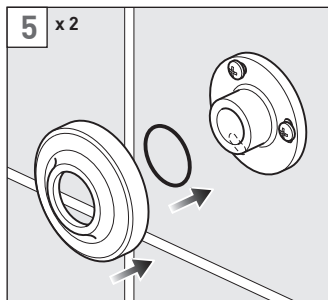

Installation

Slide both top and bottom wall brackets onto the riser and place against the wall.

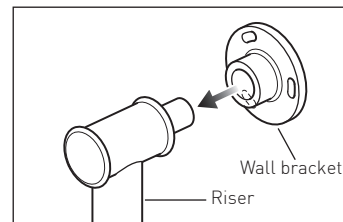

Make sure that the riser is vertical and mark the 3 fixing holes in both wall brackets with a pencil.

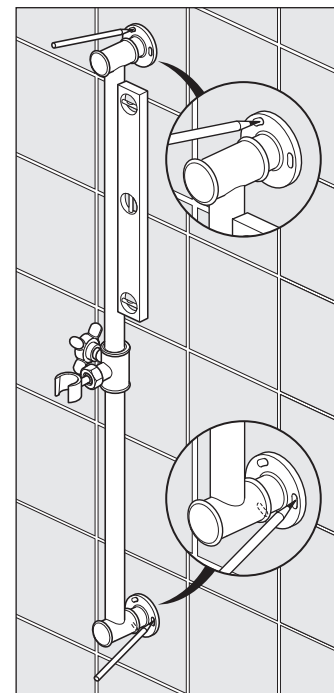

Installation

⚠ Warning! Please check for any hidden cables and pipes before drilling holes in the wall. Drill the marked holes to a suitable depth for the wall plugs and secure with supplied screws. Repeat for the other bracket.

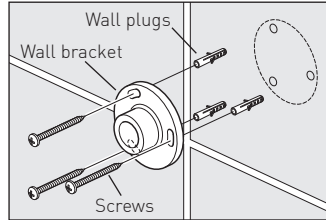

Slide on the O-ring and cover onto the bracket.

Repeat for the other bracket.

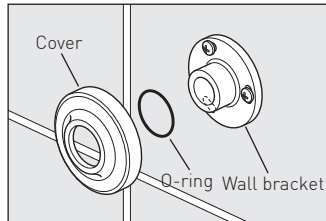

Slide the riser into both wall brackets.

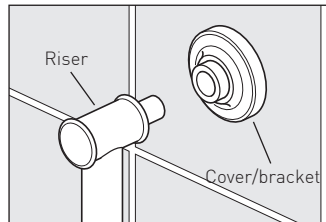

Make sure that the riser is vertical and secure in position using the two grub screws on the underside of the wall bracket.

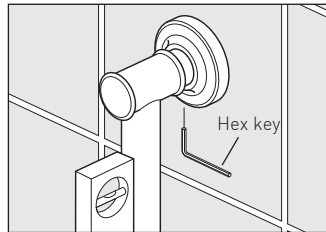

Installation

Handset

Place one of the rubber washer into the cone end of the hose and screw to the handset.

Place the handset into the holder.

Valve

Place the second rubber washer into the nut end of the hose and attach it to the valve.

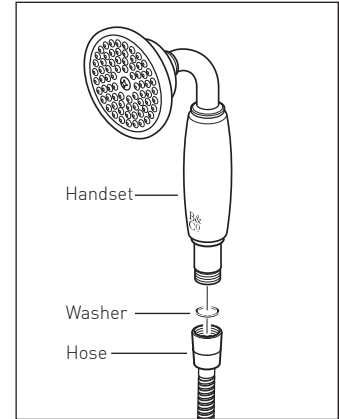

Place the handset into the holder.

Operation

Release the handle on the holder, slide the holder to the required position and retighten.

The angle of the holder can be adjusted by moving to the required position.

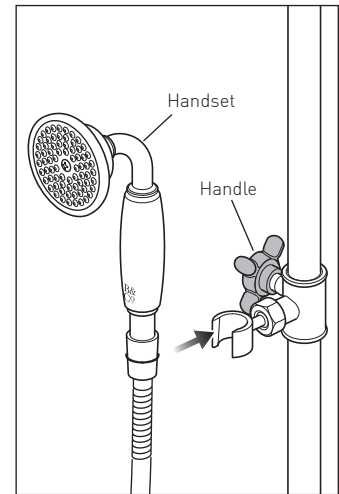

Cleaning instructions

The electroplating on this product is finished to the highest standard.

Due care needs to be taken to ensure the appearance is retained.

We recommend cleaning all products with a soft damp cloth **ONLY** and advise strongly against the use of all aggressive/corrosive cleaning products i.e. powders and liquids. If these instructions are not followed, this may invalidate your guarantee in the event of a problem occurring.

Guarantee

All VADO and Booth & Co. products come with a 2 year guarantee as standard. Within this guarantee period VADO will provide replacement parts and any labour **[SEE NOTE 1]** needed to complete the product repair.

This standard guarantee may be extended by registering your product to give up to a 15 year guarantee period. Once registered:

VADO chromed brassware and stainless steel products have a 12 year guarantee (2 years parts and labour plus 10 years parts only).

Individual by VADO and Booth & Co. products have a 15 year guarantee (2 years parts plus 13 years parts only) *with the exception of Sensori products (please see details of guarantee below).*

VADO Sensori Smart Touch and Smart Dial products have a 5 year guarantee (parts and labour).

VADO Identity and i-tech products have a 5 year guarantee (2 year parts and labour plus 3 years parts only).

All other VADO products have a 3 year guarantee (2 years parts and labour plus 1 year parts only) **[SEE NOTE 2].**

VADO electric showers have a 2 years parts and labour guarantee.

Guarantee conditions

Our products are guaranteed against manufacturing defects from the date of purchase until the expiry of the relevant guarantee period shown above.

The guarantee is only valid if:

- The product has been installed, used and maintained in accordance with VADO's instructions and subjected to normal use only.
- The defect is not due to use of an unsuitable or inadequate water or power supply.
- The defect is not due to accident, misuse, neglect or incorrect/inappropriate repair (other than by VADO or VADO authorised agents) or damage caused by foreign objects or substances.
- The extended guarantee is only available if you have completed the Guarantee Registration Process.

This can be done via the VADO website or via phone to our aftersales team. Registration must be completed within 6 months from date of purchase.

Under the extended guarantee period VADO will, at its option, offer to supply any replacement product (or component part) assessed to be defective **[SEE NOTE 3].**

The guarantee (whether standard or extended) is non-transferable to any subsequent owner. All claims under the guarantee should be notified in the first instance to our Aftersales department, contact details below, this must be done no later than the last day of the relevant guarantee period. All claims must be accompanied by proof of purchase (sales receipt or delivery note) from an official VADO dealer.

The guarantee does not extend to any consequential loss or damage.

After repair or replacement, the relevant guarantee period will be calculated from the original date of purchase.

VADO operates a policy of continuous product development and therefore reserves the right to change the product, packaging and documentation specifications without notice.

NOTES:

[1] Labour via our engineer network is only available in the UK. Attendance by a VADO engineer or sub-contract engineer will be under our standard terms and conditions.

[2] VADO spare parts and shower hoses are under a parts only guarantee.

[3] VADO reserves the right to charge in advance for a product (or replacement part) pending collection and investigation (at VADO expense) to confirm a defect is due to a manufacturing issue. If a defect is found the charge will be refunded or cancelled. This guarantee is in addition to and does not affect your statutory rights as a consumer.

Tel: 01934 745163

Email: aftersalescare@vado.com