

# SPECIFICATION SHEET

COLLECTION: WASTES & FITTINGS  
PRODUCT CODE: IND-DCV-1/2-BRG



## TAP TYPE

Wastes and Fittings

## COLLECTION NAME

Wastes & Fittings

## FINISH

Brushed Gold

## MINIMUM OPERATING PRESSURE

0.2 Bar LP

## MAXIMUM OPERATING PRESSURE

5.0 Bar HP

## GUARANTEE

3 Year Guarantee

## PLUMBING SYSTEM SUITABILITY

Gravity System, Pumped System, Combination Boiler, Pressurised System

## CONNECTIONS / FITTINGS

1/2" BSP female inlet connection 1/2" BSP Male outlet connection

## NOTES

knurled grip to aid installation  
type ED double check valve  
suitable for Fluid Category 3 risks

tel: 01934 744466  
email: [sales@vado.com](mailto:sales@vado.com)  
[www.vado.com](http://www.vado.com)

WHERE INSPIRATION FLOWS  
TAPS | SHOWERS | ACCESSORIES



# SPECIFICATION SHEET

COLLECTION: WASTES & FITTINGS  
PRODUCT CODE: IND-DCV-1/2-BRG

tel: 01934 744466  
email: [sales@vado.com](mailto:sales@vado.com)  
[www.vado.com](http://www.vado.com)

WHERE INSPIRATION FLOWS  
TAPS | SHOWERS | ACCESSORIES



# TECHNICAL DRAWING

COLLECTION: WASTES & FITTINGS  
PRODUCT CODE: IND-DCV-1/2-BRG

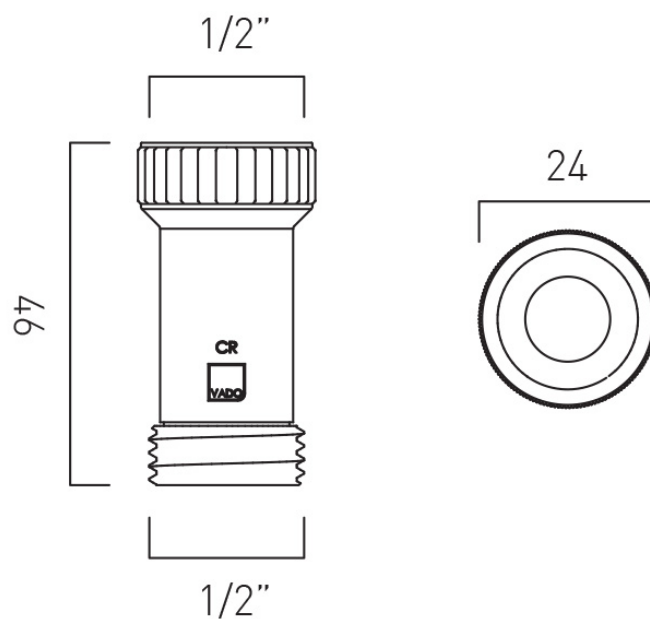

tel: 01934 744466  
email: sales@vado.com  
www.vado.com

WHERE INSPIRATION FLOWS  
TAPS | SHOWERS | ACCESSORIES

