

# SPECIFICATION SHEET

COLLECTION: AXBRIDGE  
PRODUCT CODE: BC-AXB-133-BN

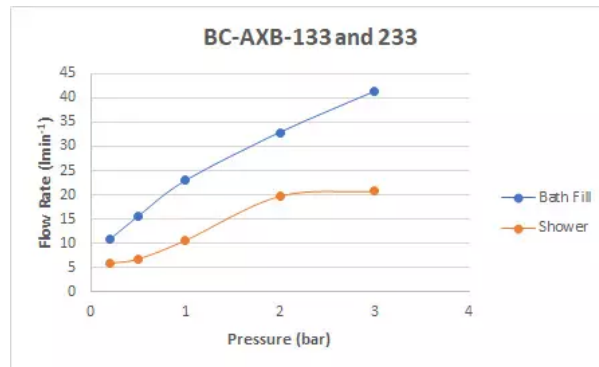

The flow rate displayed is calculated using ideal system conditions. This result should only be taken as an indication as the flow rate may vary depending on the specific in-situ configuration.

## TAP TYPE

Bath Shower Mixer

## FOR USE WITH BATH FILLER WASTE AND OVERFLOW

No

## WITH SHOWER KIT

Yes

## WITH BATH SPOUT

No

## WITH EASY-FIT BRACKETS

No

## WITH AIR-INJECTION TECHNOLOGY

No

## WITH INTEGRATED DIVERTER

No

## WITH WATER FLOW STRAIGHTENER

Yes

## WITH THERMOSTATIC TECHNOLOGY

No

tel: 01934 744466  
email: [sales@vado.com](mailto:sales@vado.com)  
[www.vado.com](http://www.vado.com)

WHERE INSPIRATION FLOWS  
TAPS | SHOWERS | ACCESSORIES



# SPECIFICATION SHEET

COLLECTION: AXBRIDGE  
PRODUCT CODE: BC-AXB-133-BN

## WITH WATER FLOW AERATOR

No

## CONNECTIONS / FITTINGS

2 x 3/4" female threaded connections

## SPARE PARTS

cold ceramic cartridge FL-511-RTC hot ceramic cartridge FL-511-LTC

## STYLE

Traditional, Cross Handles

## HOLES

2 Hole

## MOUNTING

Floor Mounted

## PLUMBING SYSTEM SUITABILITY

Pumped System, Combination Boiler, Pressurised System

## COLLECTION NAME

Axbridge

## FINISH

Bright Nickel

## MINIMUM OPERATING PRESSURE

1.0 Bar MP

## MAXIMUM OPERATING PRESSURE

5.0 Bar HP

## GUARANTEE

15 Year Guarantee

tel: 01934 744466  
email: [sales@vado.com](mailto:sales@vado.com)  
[www.vado.com](http://www.vado.com)

WHERE INSPIRATION FLOWS  
TAPS | SHOWERS | ACCESSORIES



# TECHNICAL DRAWING

COLLECTION: AXBRIDGE  
PRODUCT CODE: BC-AXB-133-BN

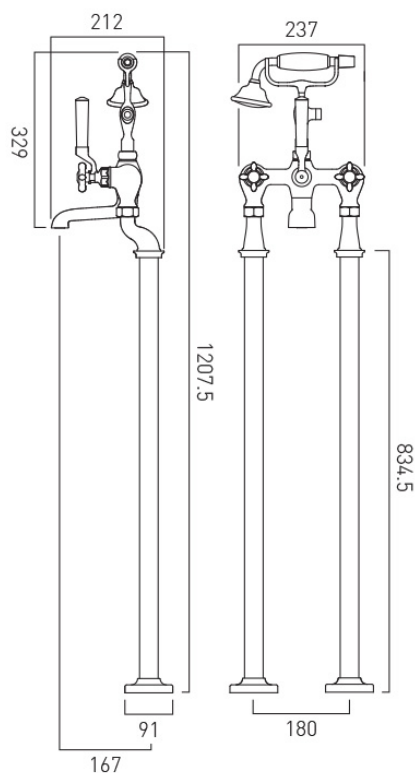

tel: 01934 744466  
email: sales@vado.com  
www.vado.com

WHERE INSPIRATION FLOWS  
TAPS | SHOWERS | ACCESSORIES

