

## customer/technical services

For any technical or installation queries please contact Vado on 01934 745163.

## guarantee

This product is guaranteed against manufacturing defects from the date of purchase until the expiry of the relevant guarantee period shown below.

### The guarantee is only valid if:-

1. The product has been installed, used and maintained in accordance with Vado's instructions and subjected to normal use only.
2. The defect is not due to use of an unsuitable or inadequate water or power supply.
3. The defect is not due to accident, misuse, neglect or repair other than by Vado or Vado authorised agents or damage caused by foreign objects or substances.
4. We have received from you the completed Guarantee Registration Form. Vado accepts no responsibility for any forms lost in the post and returns by registered means is therefore recommended.

Under this guarantee (which is non-transferable) Vado will, at its option, repair or replace free of charge any product (or replacement part) found to be defective. The guarantee does not extend to any consequential loss or damage. After repair or replacement the relevant guarantee period will be calculated from the original date of purchase.

### The relevant guarantee periods are:-

1. Twelve years on chrome finish products.
2. Three years on all other products with the exception of Stuart Turner Pumps which carry a 2 year Guarantee on Monsoon Range and 1 Year Guarantee on Showermate Range.

All claims under the guarantee must be submitted in writing to the person who supplied the product to you and must be received no later than the last day of the relevant guarantee period. All claims must be accompanied by proof of purchase (sales receipt or delivery note).

Vado operates a policy of continuous product development and therefore reserves the right to change the product, packaging and documentation specifications without notice.

This guarantee is in addition to and does not affect your statutory rights as a consumer.

### Vado

Wedmore Road, Cheddar, Somerset, England BS27 3EB  
tel 01934 744466. fax 01934 744345  
technical@vado-uk.com  
www.vado-uk.com

### GUARANTEE REGISTRATION

NAME				
ADDRESS				
	POSTCODE			
RETAILER				
ADDRESS				
	POSTCODE			
PURCHASE DATE	ARTICLE NUMBER	(SEE BOX)		
PRODUCT DESCRIPTION				
WHO INSTALLED THE PRODUCT?	RETAILER	PLUMBER	BUILDER	SELF
FOR VADO USE				



## installation & maintenance instructions

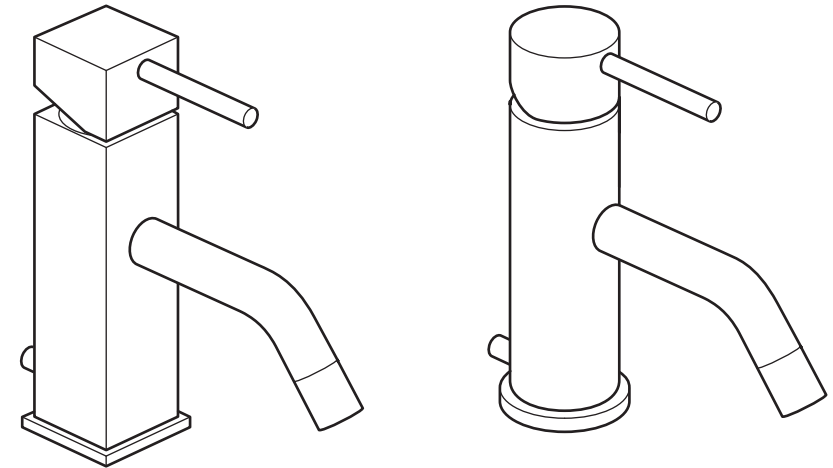

mix<sup>2</sup> proteus té

mono basin mixer with 1 1/4" pop-up waste  
smooth bodied mono basin mixer without pop-up waste

NOTE: For illustrative purposes only the mix<sup>2</sup> mono basin mixer with 1 1/4" pop-up waste installation is shown. Please follow the same procedure to install the other products.

**please leave these instructions with the customer**

## important - please read

Please read these instructions carefully before starting installation and keep for future reference.

Remove all packaging and check the product for missing parts or damage before starting installation.

Any alterations made to this product and fittings may infringe water regulations and will invalidate the guarantee.

The installation must comply with all Local/National Water Supply Authority Regulations/Byelaws and Building and Plumbing (UK:BS6700) Regulations.

We strongly recommend that you use a qualified and registered plumber.

## general installation

These fittings are mixing devices and therefore water supplies must be reasonably balanced.

Where connections are made to the mains cold water supply, WRC approved single check valves must be fitted to both hot and cold inlets. This is a stated requirement of Water Supply (Water Fittings) Regulations 1999 Schedule 2, Section 6 G15.13.2

Before making any inlet pipe connections, all supply pipes MUST be thoroughly flushed to remove debris. Failure to do so could result in damage or low flow from the mixer unit. Water Supply (Water Fittings) Regulations 1999 Schedule 2 Section 4 G13.1

The fitting of isolating valves to the inlet feeds is advised for ease of maintenance.

Please take great care when installing this mixer not to damage its surface.

Please note if installing in an enclosed environment, access should be left for servicing and maintenance. No costs relating to inadequate access can be accepted.

## care of the mixer

Our products are finished to the highest standard and due care needs to be taken to ensure their looks are retained.

We recommend cleaning all products with a soft damp cloth ONLY and advise strongly against the use of ALL cleaning products i.e. powders and liquids.

If the above instructions are not followed this will invalidate your guarantee in the event of a problem occurring.

## installers/users notes

## operation

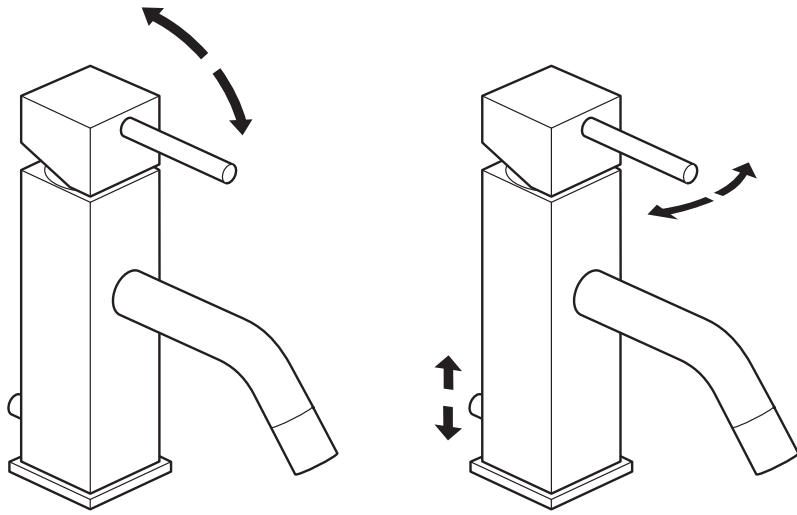

on = up off = down

hot = left cold = right

Moving the mixer lever upwards/downwards will increase/decrease the flow of water.

Moving the mixer lever from right to left will increase the water temperature.

Pull the vertical control rod up to close the waste outlet and push down to open.

## dimensions

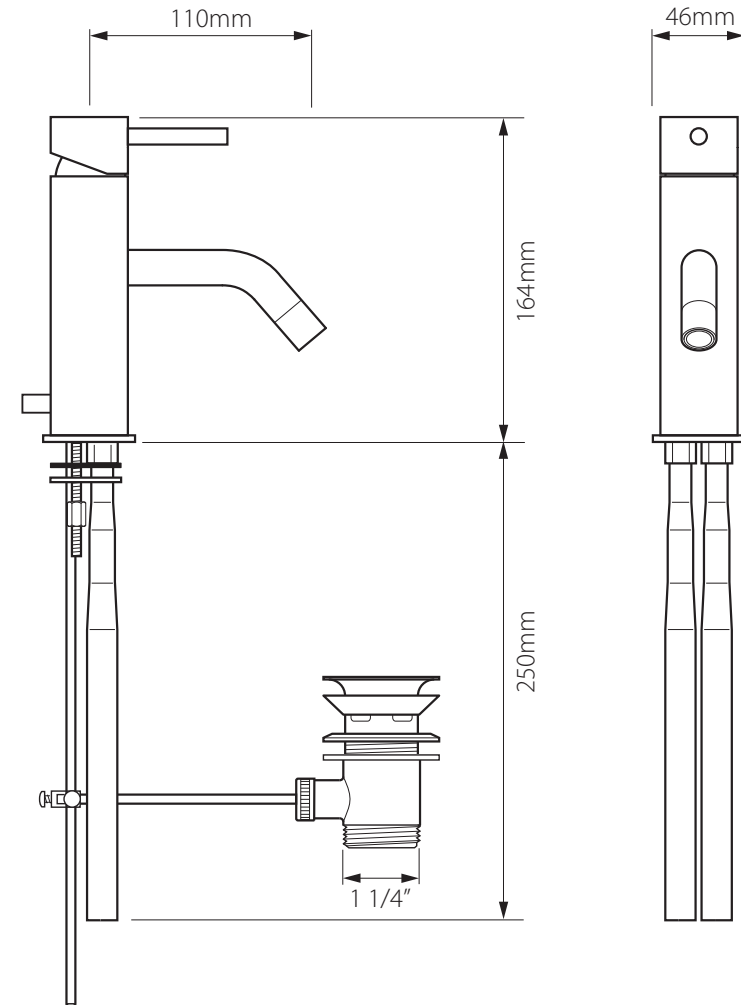

## Operating Specifications

Mono basin mixer - minimum operating pressure 0.5 bar

## installation

Before installing your new mixer, flush through the pipework to ensure removal of debris, turn off the water supply.

Screw the two copper pipes (or flexible pipes if supplied) to the mixer body, tighten using the correct size spanner, but do not over tighten.

Screw the threaded rods into the back holes in the base of the mixer body.

Position the base ring onto the bottom of the mixer body (ensure the 'O' ring is in place).

Position the mixer on the basin. From the underside of the basin slide the 'O' ring over the pipes and threaded rods followed by the metal washer and the nut (ensure the 'O' ring is in the groove in the washer). Tighten the nuts to clamp the mixer to the basin.

**CAUTION:** Do not over tighten the nuts as this may damage the basin.

Connect the water supply to the inlet pipes. The hot water should be connected to the left hand pipe.

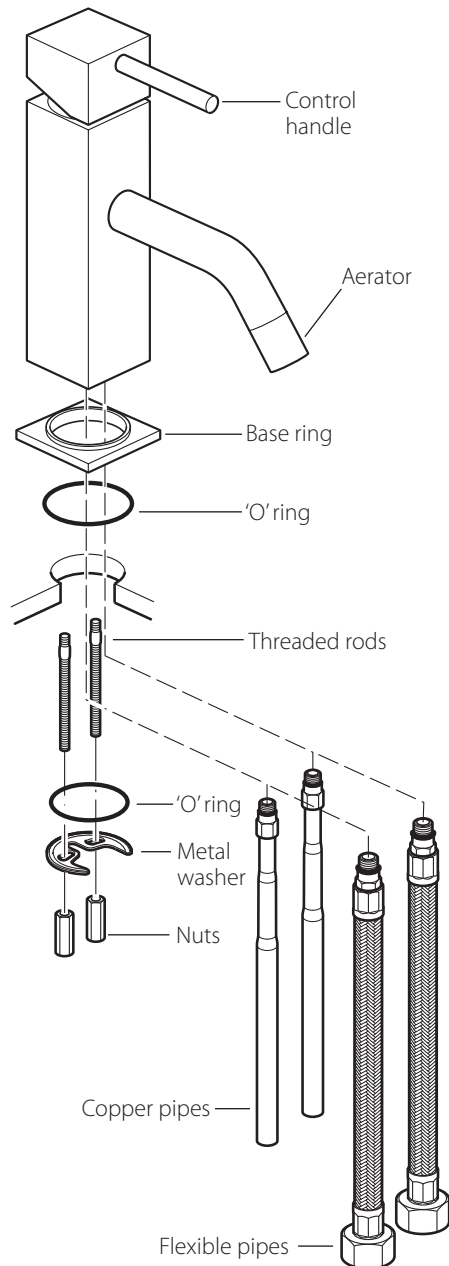

## pop-up waste assembly and installation (if applicable)

Disassemble the pop-up waste and reassemble onto the basin.

Insert the vertical control rod up through the hole the mixer body and screw into the handle ( See detail).

Unscrew the ball joint retainer on the side opening of the pop-up waste. Insert the short end of the horizontal control rod (with ball joint) into the waste and clamp in position by refitting the ball joint retainer. Do not over tighten.

Slide the control rod link onto the horizontal control rod and vertical control rod and loosely tighten.

Test the action of the pop-up waste and fully tighten the rod link. Adjust the ball joint retainer as required.

Turn on the water supply and turn the mixer on fully to flush through any possible debris from the mixer. Finally check all new connections for leaks.

