

SPECIFICATION SHEET

COLLECTION: PHASE

PRODUCT CODE: PHA-200F/CC-C/P



DESCRIPTION:

mono basin mixer
single lever
deck mounted
smooth bodied
with universal basin waste
with water flow aerator
ceramic cartridge C-009-N35R
2 x 1/2" x 400mm flexipipe connections
deck mount drill hole diameter 35mm
minimum operating pressure 0.2 bar LP

FINISH:

Chrome

FLOW REGULATOR:

FR-100/5-PLA

MINIMUM OPERATING PRESSURE:

0.2 bar LP

FLOW RATE AT 3.0 BAR FLOW PRESSURE:

5.1 l/m

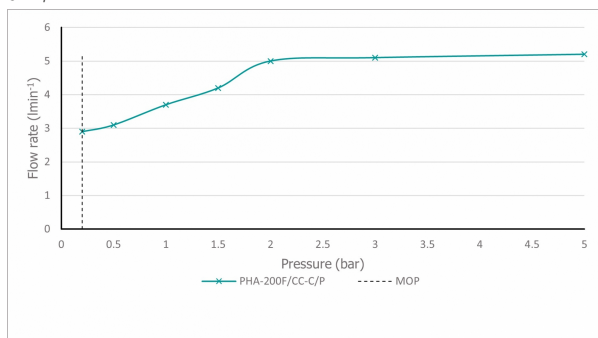

15 year guarantee

tel: 01934 744466
email: sales@vado.com
www.vado.com

where inspiration flows
taps | showering | accessories



TECHNICAL DRAWING

COLLECTION: PHASE

PRODUCT CODE: PHA-200F/CC-C/P

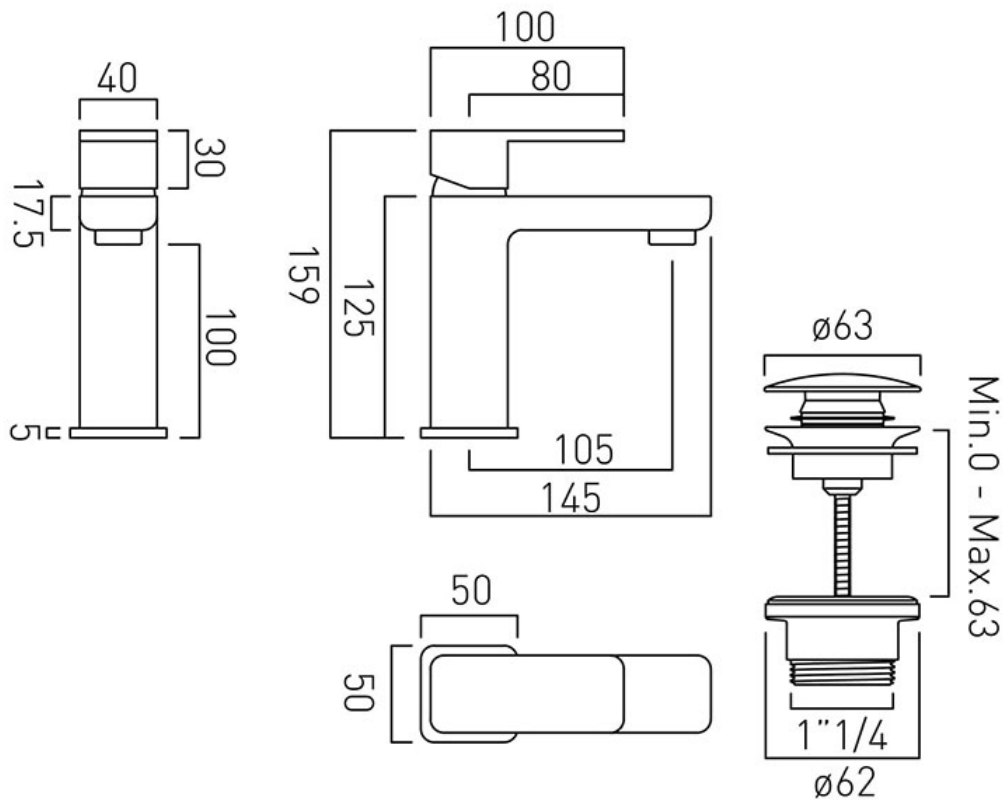

tel: 01934 744466
email: sales@vado.com
www.vado.com

where inspiration flows
taps | showering | accessories

