

This installation guide covers model:

TAB-123T/WO-ARR-CP
TAB-223T/WO-ARR-CP

ARRONDI™

2 handle, 2 outlet thermostatic shower valve

Installation Guide

TAB-123T/WO-ARR-CP
TAB-223T/WO-ARR-CP



WHERE
INSPIRATION
FLOWS

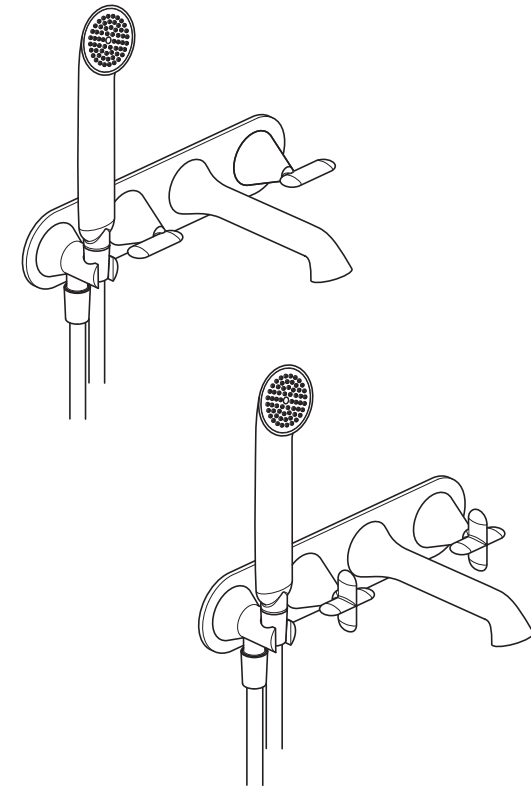

VADO
Wedmore Road Cheddar Somerset England BS27 3EB
tel 01934 744466
fax 01934 744345
www.vado.com
sales@vado.com

Version 1, 1-4-22

CONRAN AND
PARTNERS



Important - Please Read

Please read these instructions carefully before starting installation and keep for future reference.

Remove all packaging and check the product for missing parts or damage before starting installation.

Any alterations made to this product and fittings may infringe water regulations and will invalidate the guarantee.

The installation must comply with all Local/National Water Supply Authority Regulations/Byelaws and Building and Plumbing Regulations.

To be installed in accordance with BS EN806.

We strongly recommend that you use a qualified and registered plumber.

General Installation

This fitting is a mixing device and therefore water supplies should be reasonably balanced.

When installed, the fitting must comply with the requirements of the Water Supply (Water Fittings) Regulations 1999 and Scottish Byelaws 2004.

For further information, contact the Water Regulations department of your local water supplier (see the WRAS website www.wras.co.uk for details) or the Water Regulations Advisory Scheme by email (info@wras.co.uk) or telephone: 01495848454.

Before making any inlet pipe connections, all supply pipes MUST be thoroughly flushed to remove debris. Failure to do so could result in damage or low flow from the mixer unit.

The fitting of isolating valves to the inlet feeds is advised for ease of maintenance.

Please take great care when installing this mixer not to damage its surface.

Please note if installing in an enclosed environment, access should be left for servicing and maintenance. No costs relating to inadequate access can be accepted.

Operating Specifications

Operating Pressure

Minimum operating pressure **1 bar**

Maximum operating pressure **5 bar**

Contents of Packaging



Installation guide &
User manual

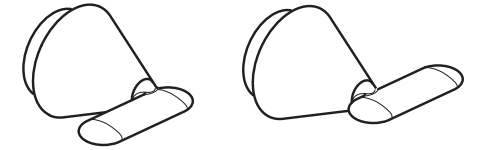

ARR-123 handles to suit your model

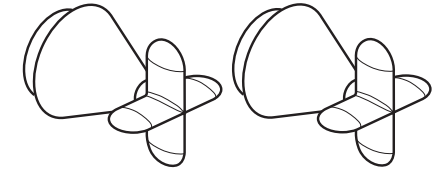

ARR-223 handles to suit your model

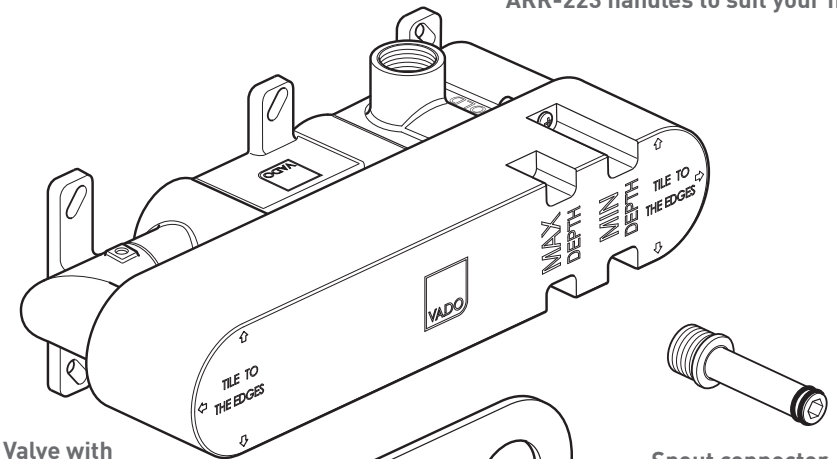

Valve with
Mortar guard

Spout connector

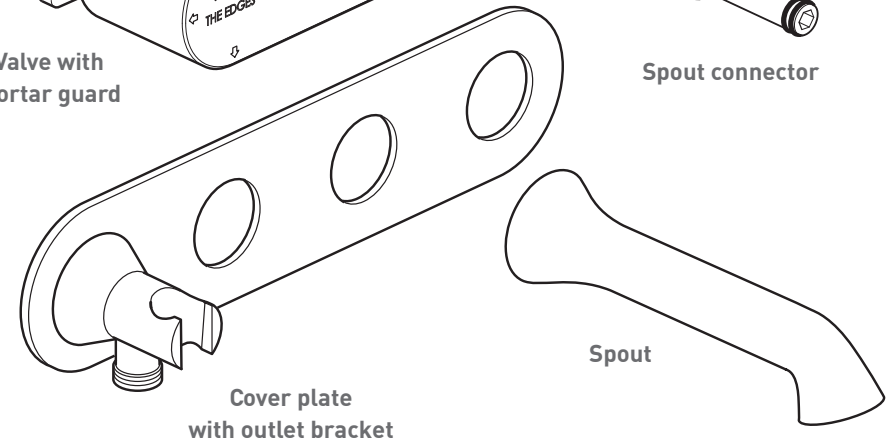

Cover plate
with outlet bracket

Spout

Contents of Packaging

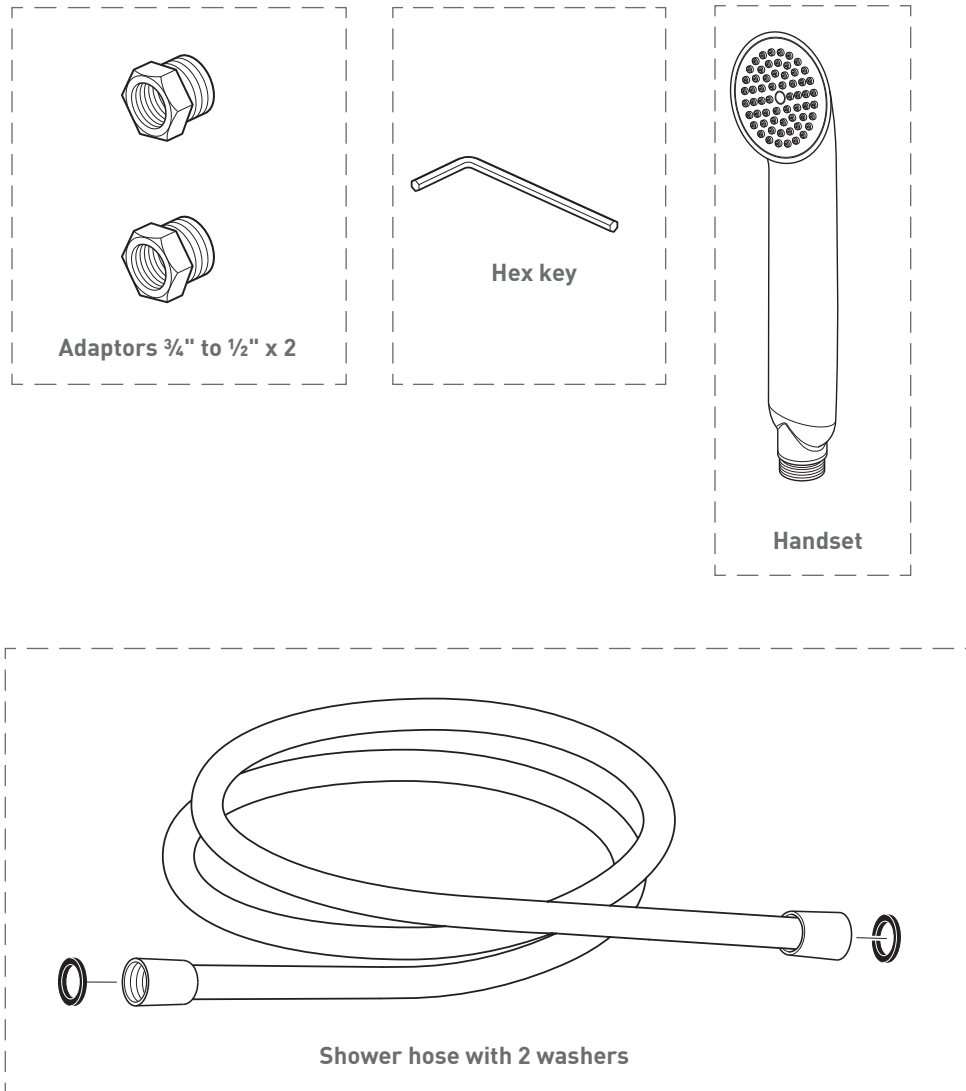

Dimensions

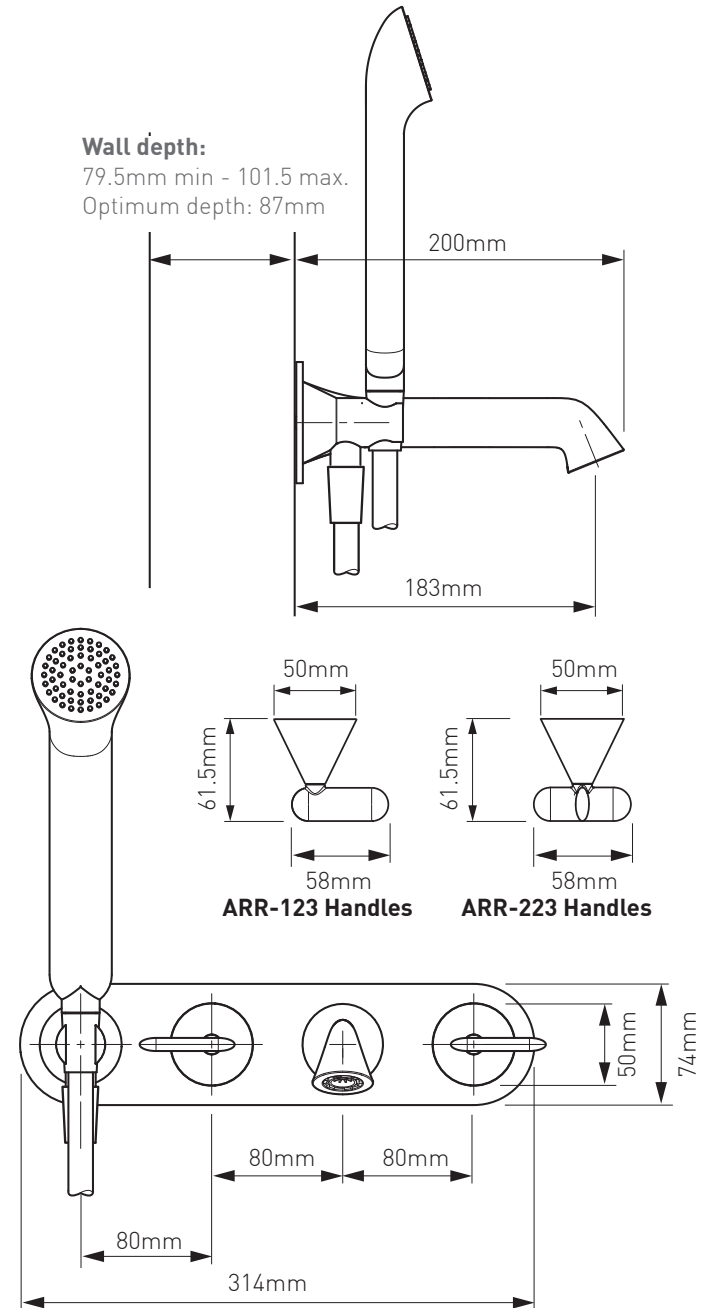

Installation - Quick Guide

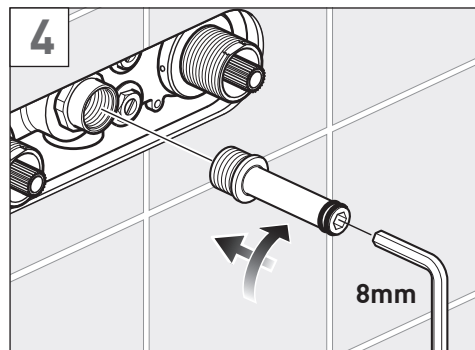
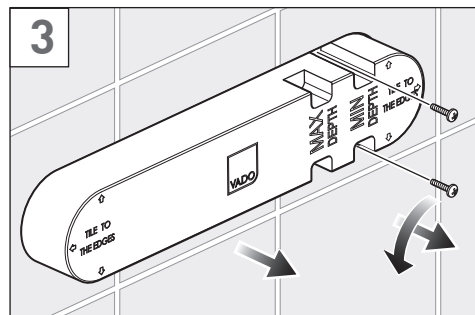
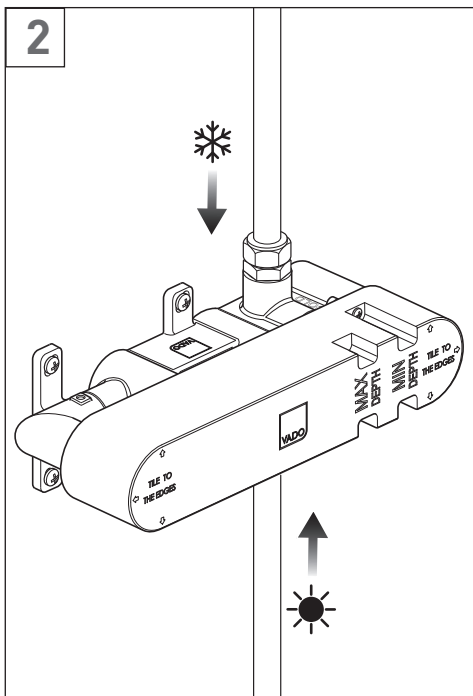
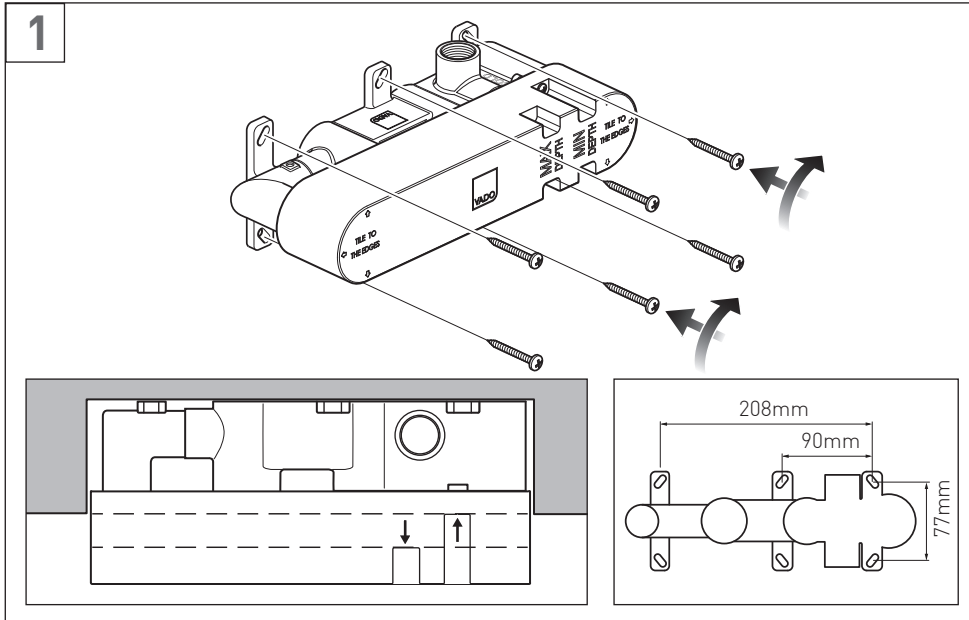

Installation - Quick Guide

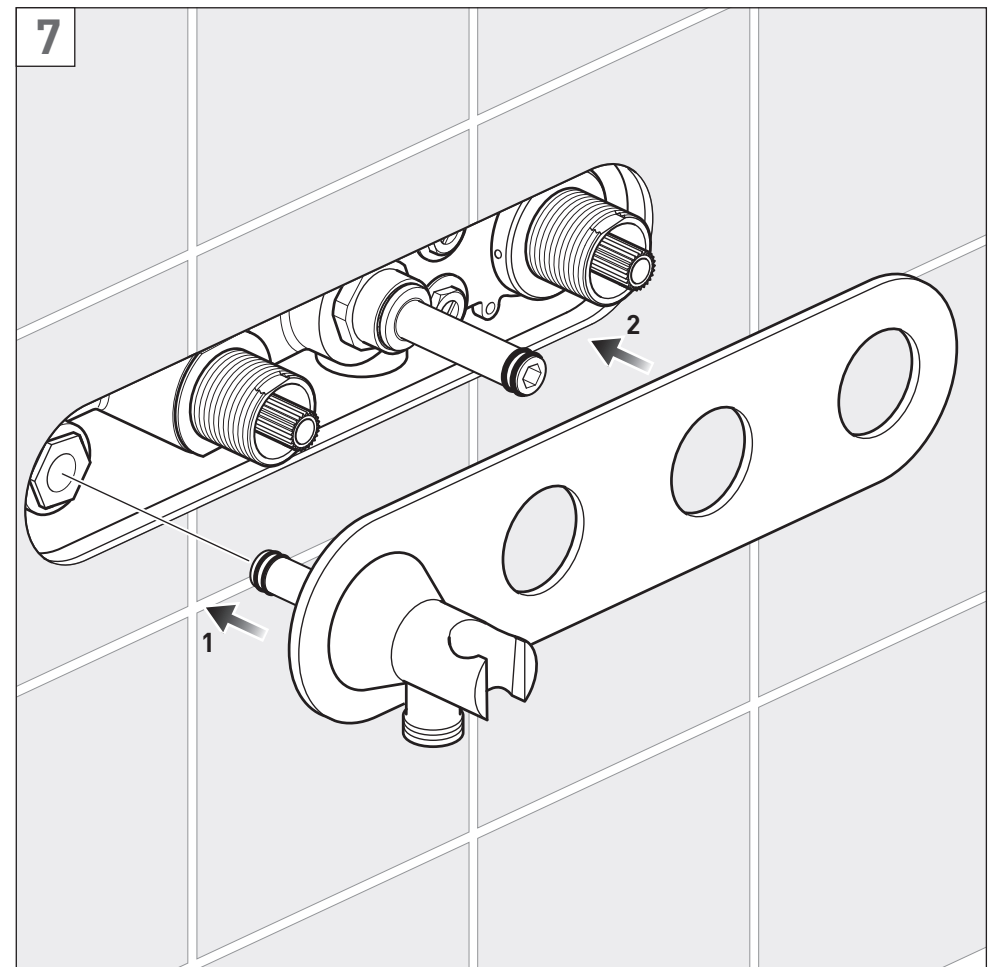
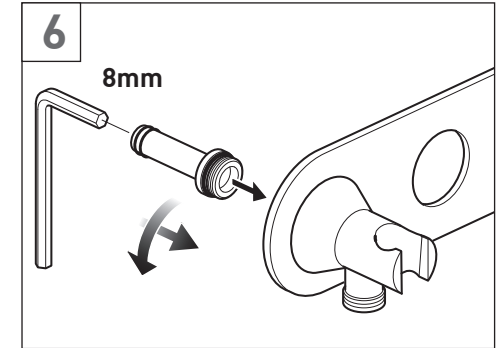
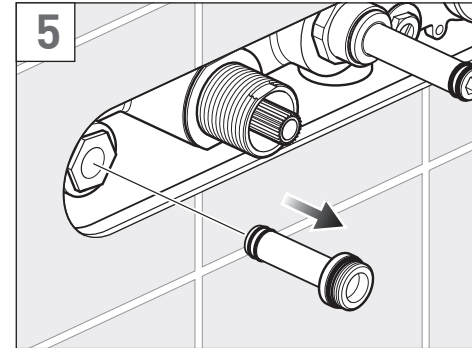

Installation - Quick Guide

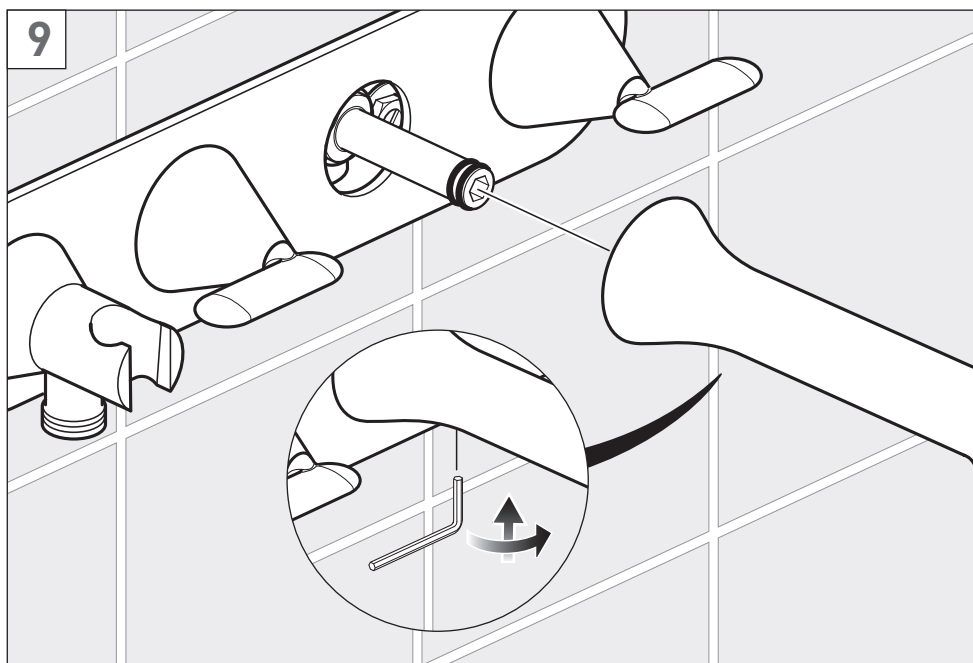
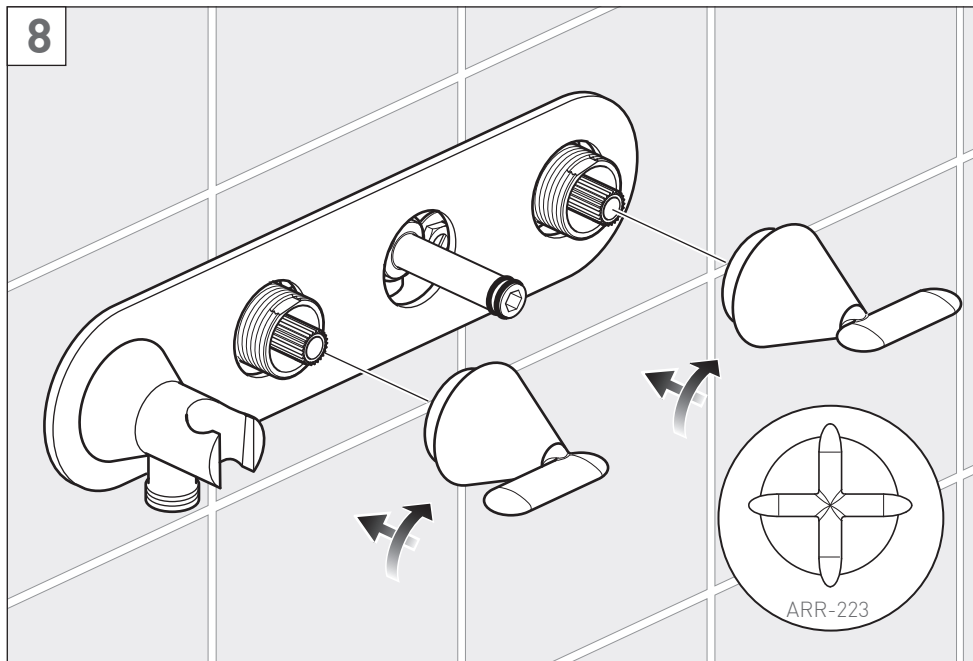

Installation - Quick Guide

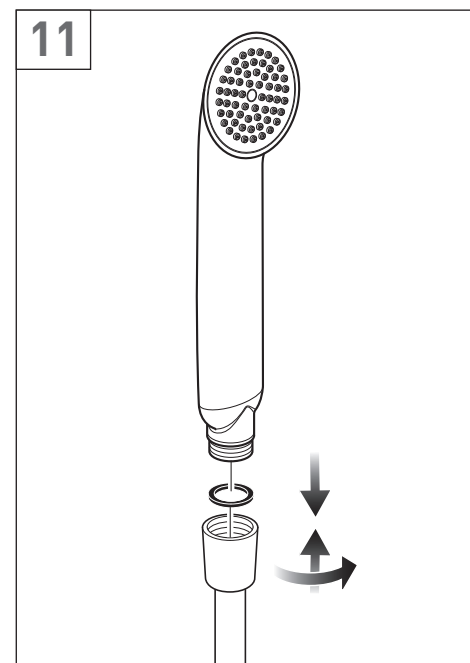
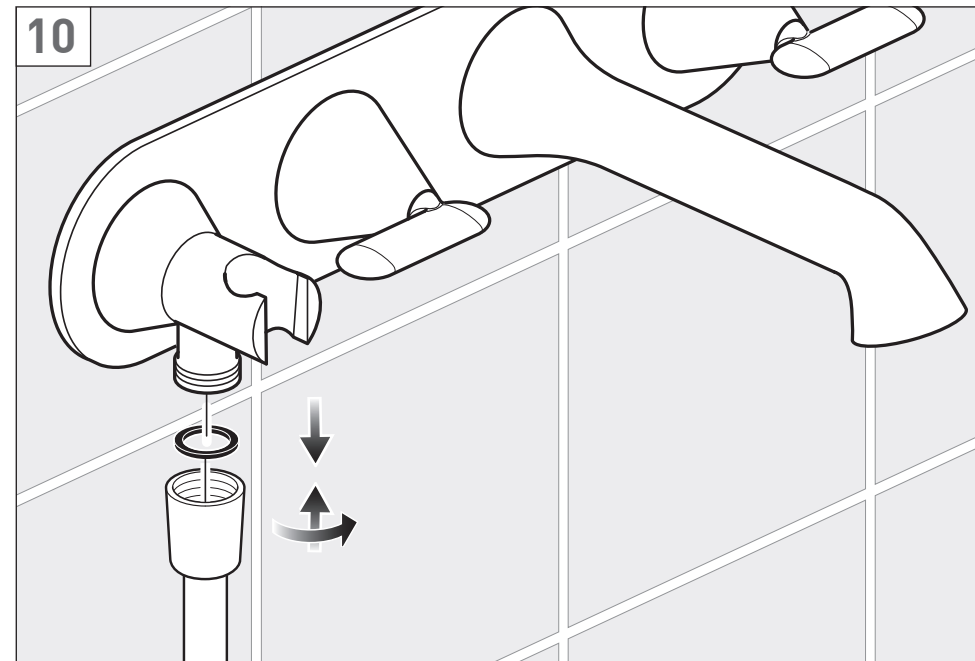

Installation

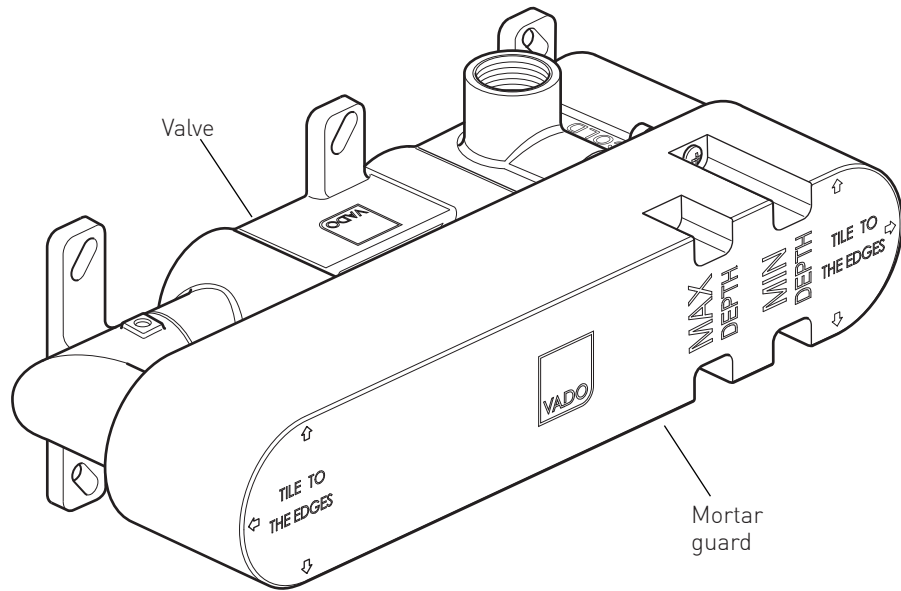

Flush pipe work thoroughly before fitting the valve.

⚠ Warning! Please check for any hidden cables and pipes before drilling holes in the wall.

The valve must be set into the wall between (79.5mm minimum - 101.5 maximum. Optimum depth: 87mm).

If you are fitting the valve to a partition wall or a wall of particularly soft substrate you will need specialist fixings.

Please contact VADO or retailer for WG-STUDFAST-C-S/S fixing.

Mortar guard

During installation please leave the mortar guard secured to the valve to avoid damage to the product and protect the internals during tiling etc.

Installation

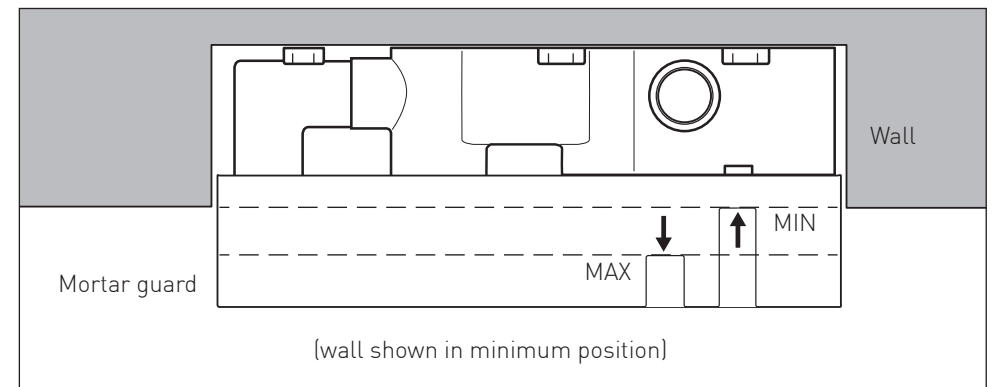
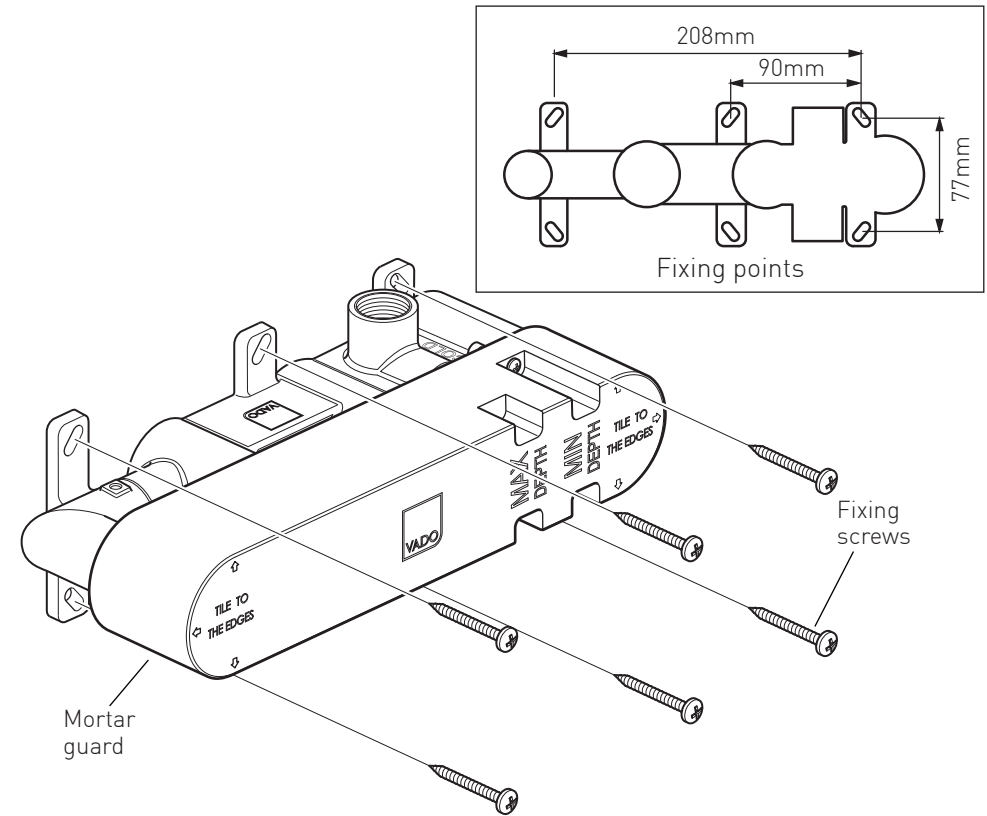

Select the position for the shower valve and offer the shower valve to the wall, make sure the valve is level and mark the 6 fixing points with a suitable pencil, see above for dimensions. Remove the shower valve from the wall, drill the holes to a suitable depth for the wall plugs and secure with suitable screws.

Installation

Connect hot supply to the lower inlet of the valve and cold supply to the upper inlet.

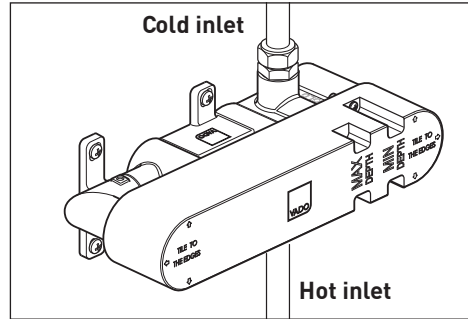

Finish the wall by tiling up to the mortar guard, keep the final finished wall surface between the min and max marks.

Unscrew the 2 mortar guard screws and remove from the wall.

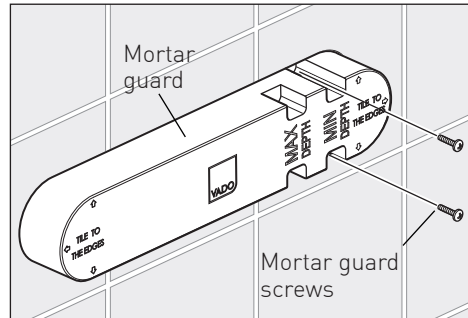

Screw spout connector into the outlet on the valve. Tighten using a 8mm hex key.

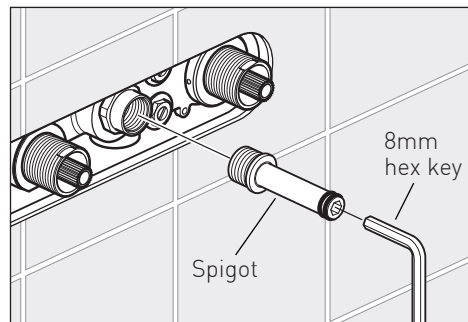

Pull out the spigot from the outlet on the left side of valve.

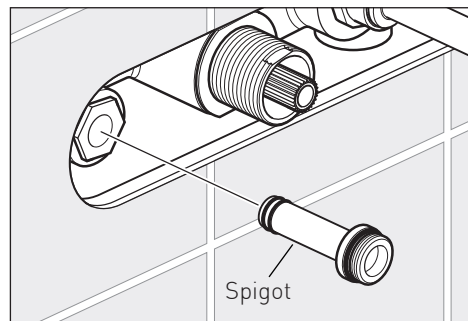

Installation

Screw spigot into the outlet on the back of the plate. Tighten using a 8mm hex key.

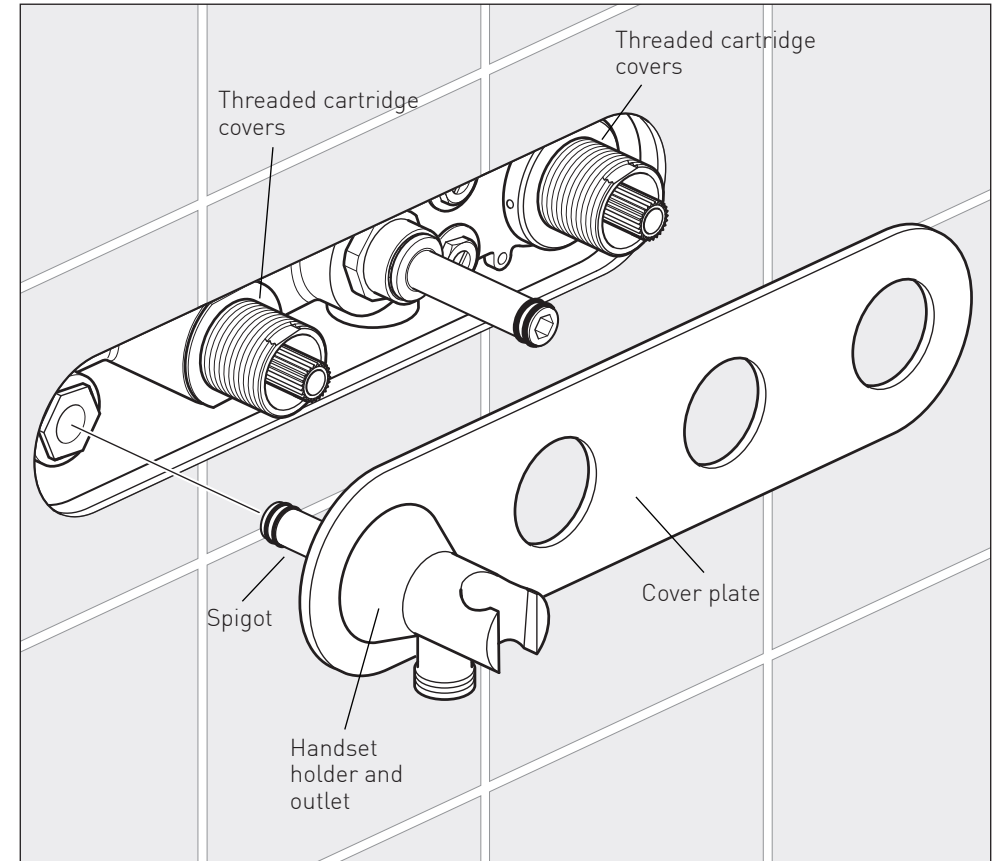
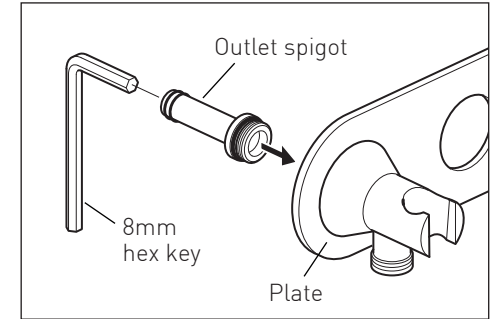

Guide the handset holder with spigot attached partially onto the valve and then slide the cover plate over the threaded cartridge covers. Push on the cover plate and handset holder. Apply a thin bead of silicone around the outside to seal against the tiled surface.

Installation

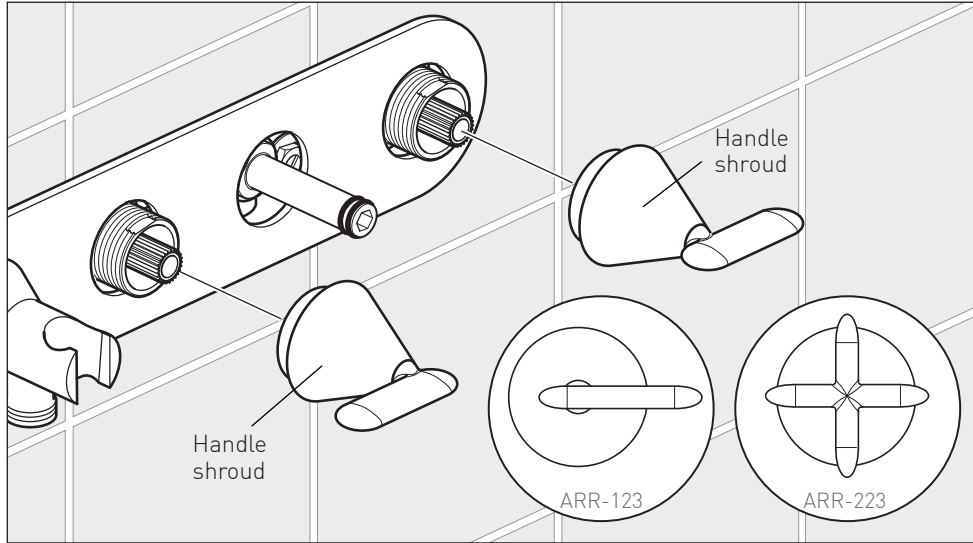

Carefully slide the handles onto spline of the valve. While holding the handle in the horizontal position screw the shroud until touches the cover plate.
For the ARR-223 the levers should be in the vertical/horizontal position.

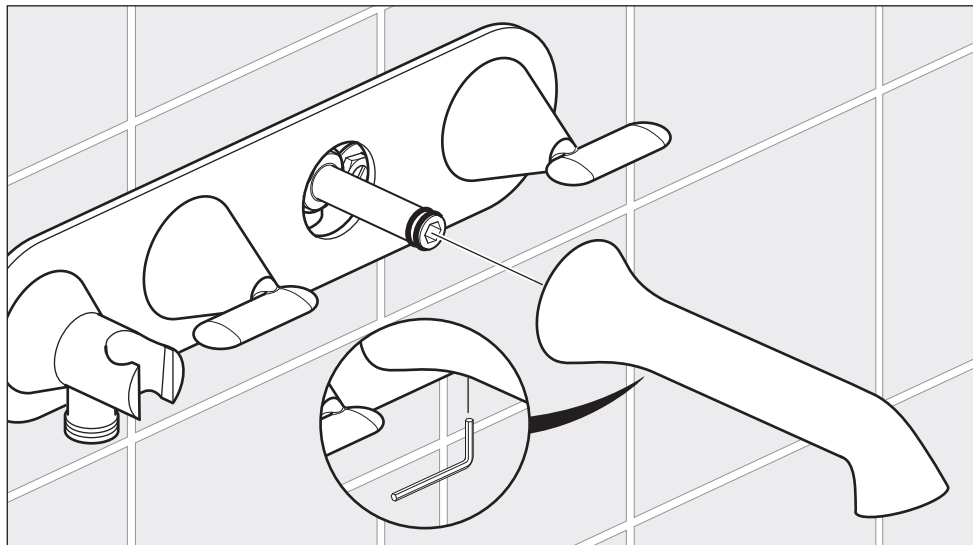

Slide the spout onto the exposed spigot up to the plate.
Tighten the grub screw on the underside of the spout to secure it to the spigot.

Installation - Handset

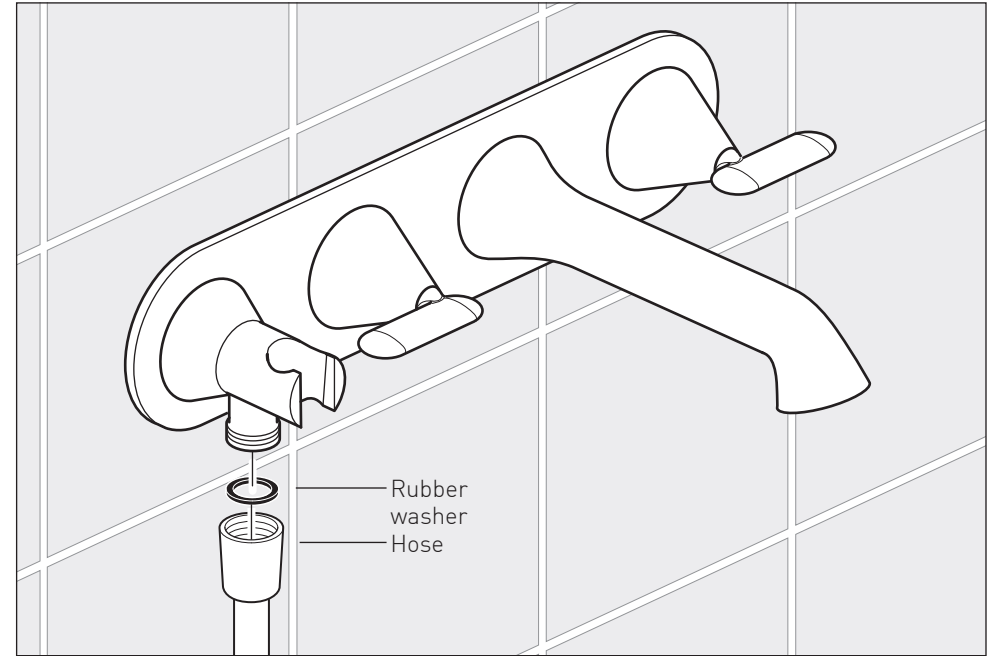

Handset outlet

Place a rubber washer into either end of the hose and attach it to the handset outlet (see above).

Handset

Place the other rubber washer into the other end of the hose and screw to the handset (see right).

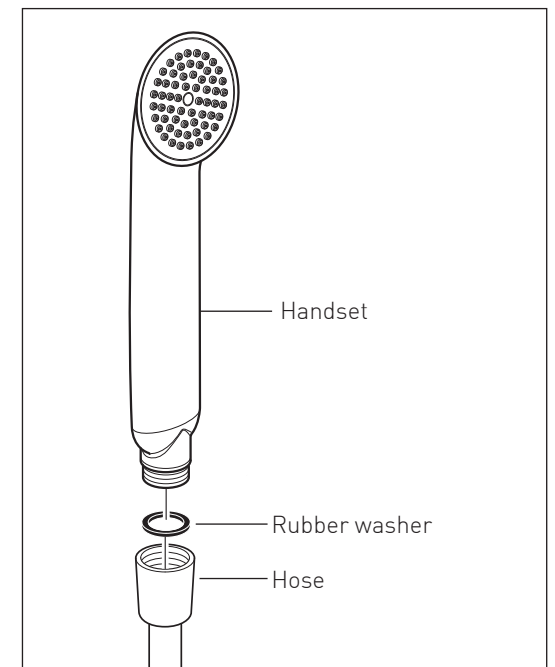

Temperature Commissioning

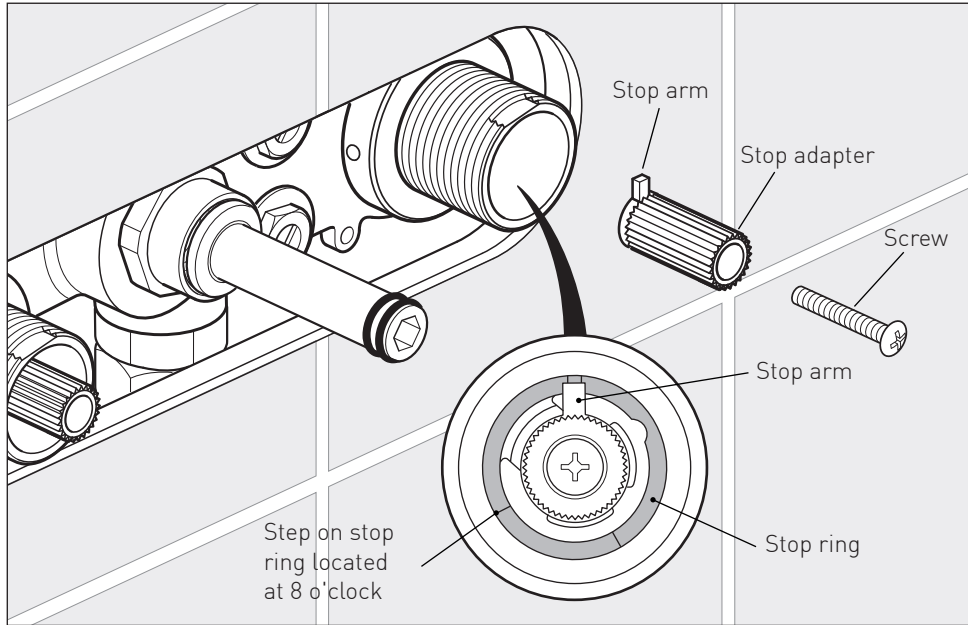

Note: Mixed water temperature at terminal fitting should never exceed 46° C.

The valve has been factory set under balance pressures and hot water supply at 65°C. When your specific operating conditions are significantly different from the above, the temperature of the water may vary from the setting.

When the difference is too great, you can adjust the calibration of the valve to suit individual requirements of the installation:

1. Check the temperature of the water being delivered from the outlet with a thermometer, when the stop arm is located at 12 o'clock.

Note: Temperature readings should be taken at normal flow rate after allowing for the system to stabilise.

2. If the temperature is not 38°C proceed to reset the calibration as follows:

Remove the stop adaptor.

Do not remove the plastic stop ring.

Please continue on next page.

Temperature Commissioning

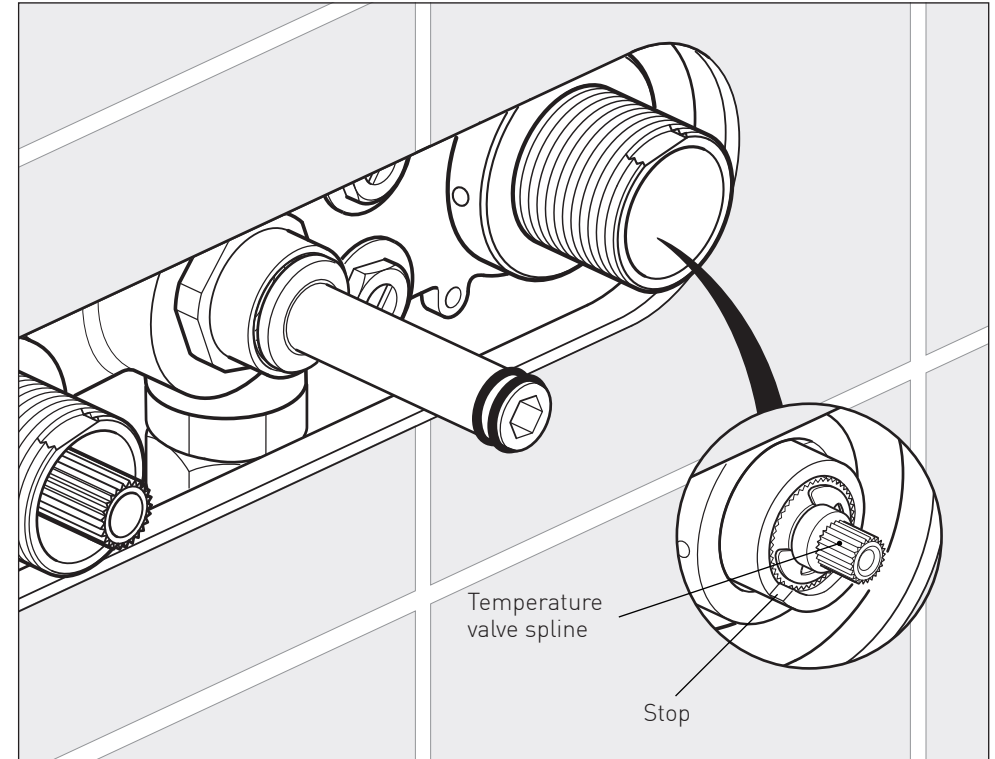

Turn the spline of the thermostatic valve clockwise to decrease the temperature and anti-clockwise to increase the temperature until 38°C is achieved at outlet.

Note: The sensing part of the thermometer probe must be fully submerged in the water that is to be tested.

Replace the stop adaptor making sure that the arm is located at 12 o'clock

When the handle is attached (see page 14) ensure the temperature does not exceed 46°C when turned entirely anti-clockwise.

Your valve setting is now commissioned.

Notes:

Notes: