

# SPECIFICATION SHEET

COLLECTION: CAMEO  
PRODUCT CODE: CAM-109S-CP

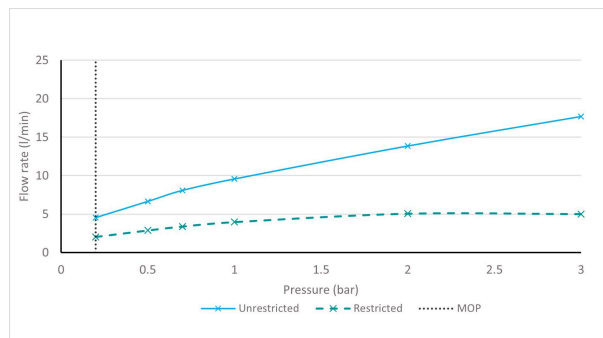

## TAP TYPE

Basin Mixer

## COLLECTION NAME

Cameo

## FINISH

Chrome

## RECOMMENDED FLOW REGULATOR

5 l/min Flow Regulator

## MINIMUM OPERATING PRESSURE

1.0 Bar MP

## GUARANTEE

15 Year Guarantee

## HANDLES

Single Lever

## MIN-MAX WALL MOUNT

53-73mm

## WITH ECOTURN COLD START TECHNOLOGY

No

tel: 01934 744466  
email: sales@vado.com  
www.vado.com

WHERE INSPIRATION FLOWS  
TAPS | SHOWERS | ACCESSORIES



# SPECIFICATION SHEET

COLLECTION: CAMEO  
PRODUCT CODE: CAM-109S-CP

## WITH WATER FLOW STRAIGHTENER

No

## WITH WATER FLOW AERATOR

Yes

## CONNECTIONS / FITTINGS

2 x 1/2" inlets

## SPARE PARTS

ceramic cartridge C-002-N30

## WALL HOLE DRILL DIAMETER

spout 30-60mm handle 50-60mm, tile-to-mortar guard included

## WASTE

None (Smooth Bodied)

## STYLE

Square

## HOLES

2 Hole

## MOUNTING

Wall Mounted

## PLUMBING SYSTEM SUITABILITY

Combination Boiler



# TECHNICAL DRAWING

COLLECTION: CAMEO  
PRODUCT CODE: CAM-109S-CP

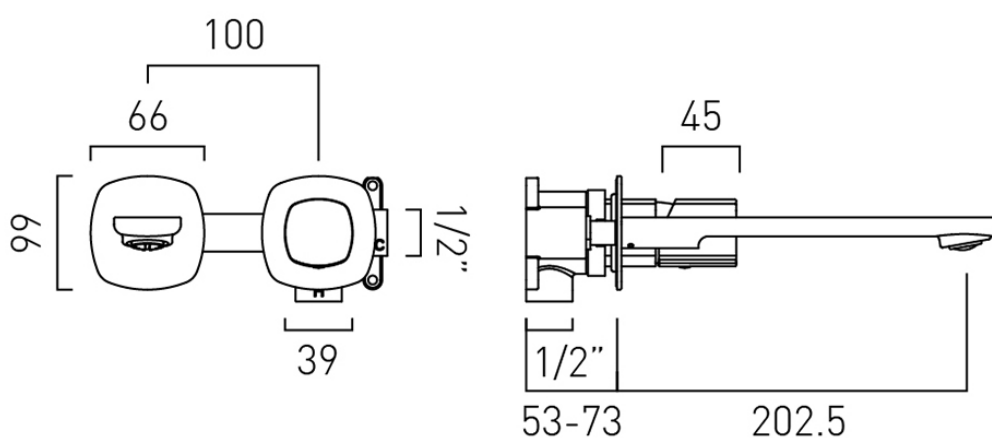

tel: 01934 744466  
email: sales@vado.com  
www.vado.com

WHERE INSPIRATION FLOWS  
TAPS | SHOWERS | ACCESSORIES

