

SPECIFICATION SHEET

COLLECTION: NEBULA
PRODUCT CODE: IND-RO/20-BRG

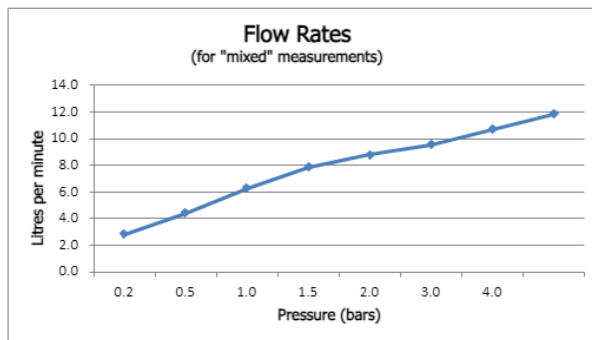
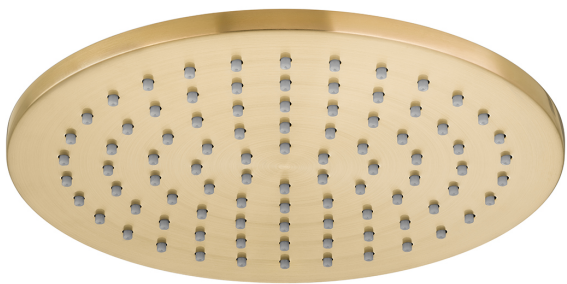

The flow rate displayed is calculated using ideal system conditions. This result should only be taken as an indication as the flow rate may vary depending on the specific in-situ configuration.

PLUMBING SYSTEM SUITABILITY

Gravity System, Combination Boiler

STYLE

Round

CONNECTIONS / FITTINGS

1/2" female inlet

WITH AIR-INJECTION TECHNOLOGY

No

FUNCTIONS

Single Function

RUB-CLEAN NOZZLES

No

SELF-CLEANING

No

SHOWER HEAD SIZE

200mm (8")

COLLECTION NAME

Nebula

tel: 01934 744466
email: sales@vado.com
www.vado.com

WHERE INSPIRATION FLOWS
TAPS | SHOWERS | ACCESSORIES



SPECIFICATION SHEET

COLLECTION: NEBULA
PRODUCT CODE: IND-RO/20-BRG

FINISH

Brushed Gold

MINIMUM OPERATING PRESSURE

0.2 Bar LP

MAXIMUM OPERATING PRESSURE

5.0 Bar HP

GUARANTEE

15 Year Guarantee

tel: 01934 744466
email: sales@vado.com
www.vado.com

WHERE INSPIRATION FLOWS
TAPS | SHOWERS | ACCESSORIES



TECHNICAL DRAWING

COLLECTION: NEBULA
PRODUCT CODE: IND-RO/20-BRG

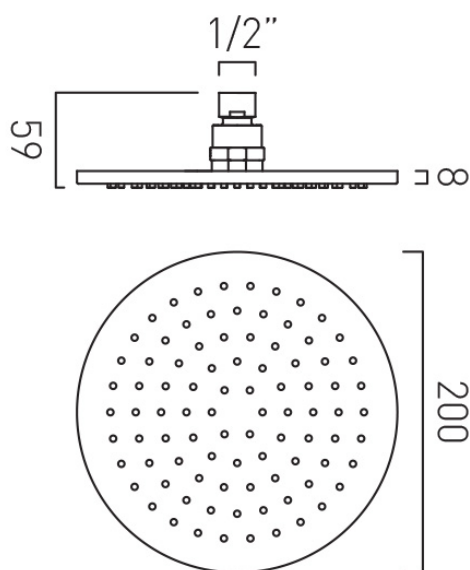

tel: 01934 744466
email: sales@vado.com
www.vado.com

WHERE INSPIRATION FLOWS
TAPS | SHOWERS | ACCESSORIES

