

SPECIFICATION SHEET

COLLECTION: CAMEO
PRODUCT CODE: CAM-209S-CP

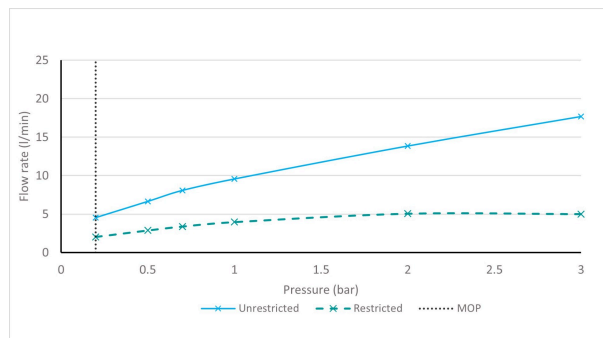
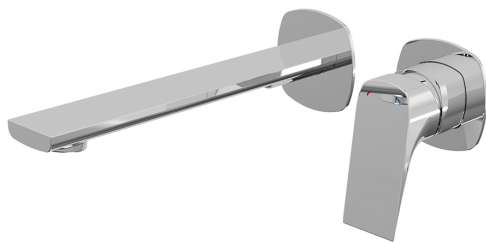

The flow rate displayed is calculated using ideal system conditions. This result should only be taken as an indication as the flow rate may vary depending on the specific in-situ configuration.

TAP TYPE

Basin Mixer

COLLECTION NAME

Cameo

FINISH

Chrome

RECOMMENDED FLOW REGULATOR

5 l/min Flow Regulator

MINIMUM OPERATING PRESSURE

1.0 Bar MP

MAXIMUM OPERATING PRESSURE

5.0 Bar HP

GUARANTEE

15 Year Guarantee

HANDLES

Single Lever

MIN-MAX WALL MOUNT

53-73mm

tel: 01934 744466
email: sales@vado.com
www.vado.com

WHERE INSPIRATION FLOWS
TAPS | SHOWERS | ACCESSORIES



SPECIFICATION SHEET

COLLECTION: CAMEO
PRODUCT CODE: CAM-209S-CP

WITH ECOTURN COLD START TECHNOLOGY

No

WITH WATER FLOW STRAIGHTENER

No

WITH WATER FLOW AERATOR

Yes

CONNECTIONS / FITTINGS

2 x 1/2" inlets

SPARE PARTS

ceramic cartridge C-002-N30

WALL HOLE DRILL DIAMETER

spout 30-60mm handle 50-60mm

WASTE

None (Smooth Bodied)

STYLE

Square

HOLES

2 Hole

MOUNTING

Wall Mounted

PLUMBING SYSTEM SUITABILITY

Combination Boiler



TECHNICAL DRAWING

COLLECTION: CAMEO
PRODUCT CODE: CAM-209S-CP

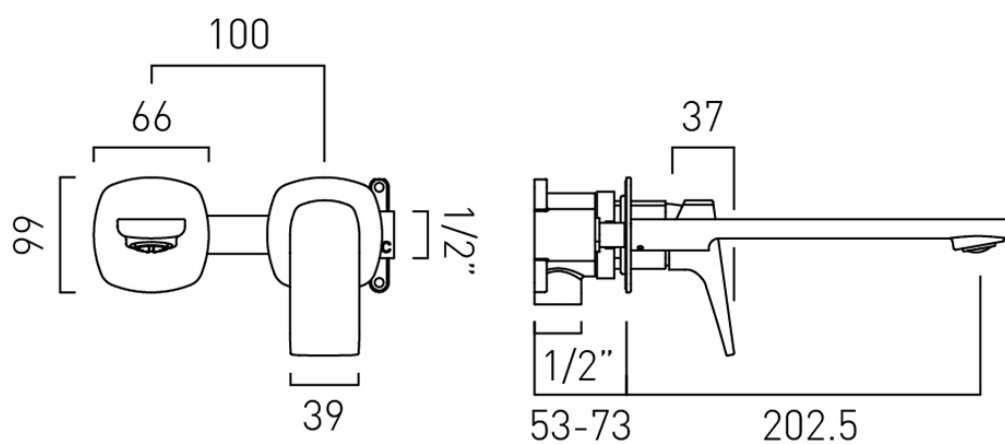

tel: 01934 744466
email: sales@vado.com
www.vado.com

WHERE INSPIRATION FLOWS
TAPS | SHOWERS | ACCESSORIES

