



BOOTH & Co.

ENGLAND

This instruction booklet covers model:

BC-AXB-148/2-CP
BC-AXB-148/2-BN

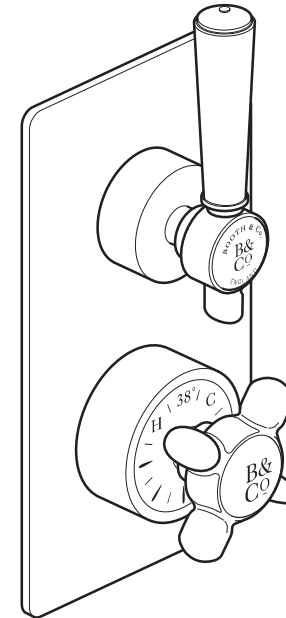

VADO
Wedmore Road, Cheddar,
Somerset, England BS27 3EB
tel 01934 744466
fax 01934 744345
www.vado.com
sales@vado.com

Version 1, 1-5-19

AXBRIDGE

BC-AXB-148/2-CP
BC-AXB-148/2-BN
INSTALLATION GUIDE

BOOTH & Co.
ENGLAND

Important - please read

Please read these instructions carefully before starting installation and keep for future reference.

Remove all packaging and check the product for missing parts or damage before starting installation.

Any alterations made to this product and fittings may infringe water regulations and will invalidate the guarantee.

The installation must comply with all Local/National Water Supply Authority Regulations/Byelaws and Building and Plumbing Regulations.
To be installed in accordance with BS EN806.

We strongly recommend that you use a qualified and registered plumber.

General installation

This fitting is a mixing device and therefore water supplies should be reasonably balanced.

When installed, the fitting must comply with the requirements of the Water Supply (Water Fittings) Regulations 1999 and Scottish Byelaws 2004.

For further information, contact the Water Regulations department of your local water supplier (see the WRAS website www.wras.co.uk for details) or the Water Regulations Advisory Scheme by email (info@wras.co.uk) or telephone: 01495848454.

Before making any inlet pipe connections, all supply pipes MUST be thoroughly flushed to remove debris. Failure to do so could result in damage or low flow from the mixer unit. Water Supply (Water Fittings) Regulations 1999 Schedule 2 Section 13.

The fitting of isolating valves to the inlet feeds is advised for ease of maintenance.

Please take great care when installing this mixer not to damage its surface.

Please note if installing in an enclosed environment, access should be left for servicing and maintenance. No costs relating to inadequate access can be accepted.

Operating Specifications

Operating Pressure

Minimum operating pressure for shower **0.2 bar**

Minimum operating pressure for bath **1 bar**

Maximum operating pressure **5 bar**

Contents of Packaging

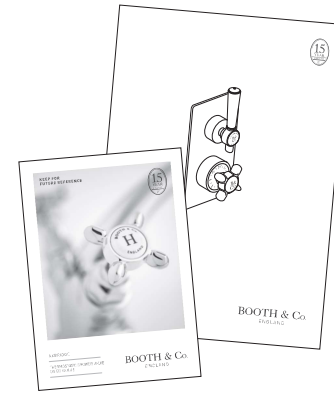

Installation guide &
User manual

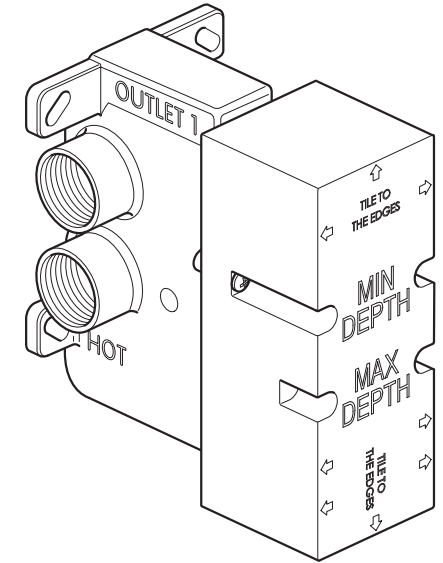

Valve with mortar guard

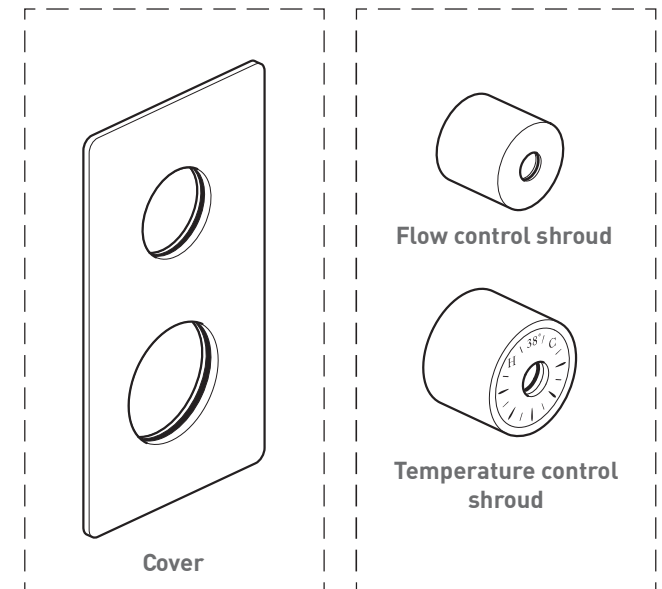

Contents of Packaging

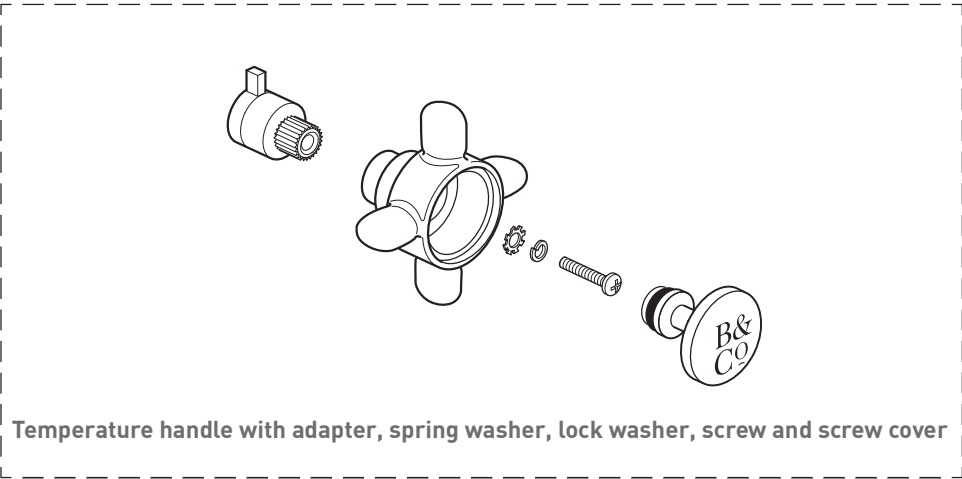
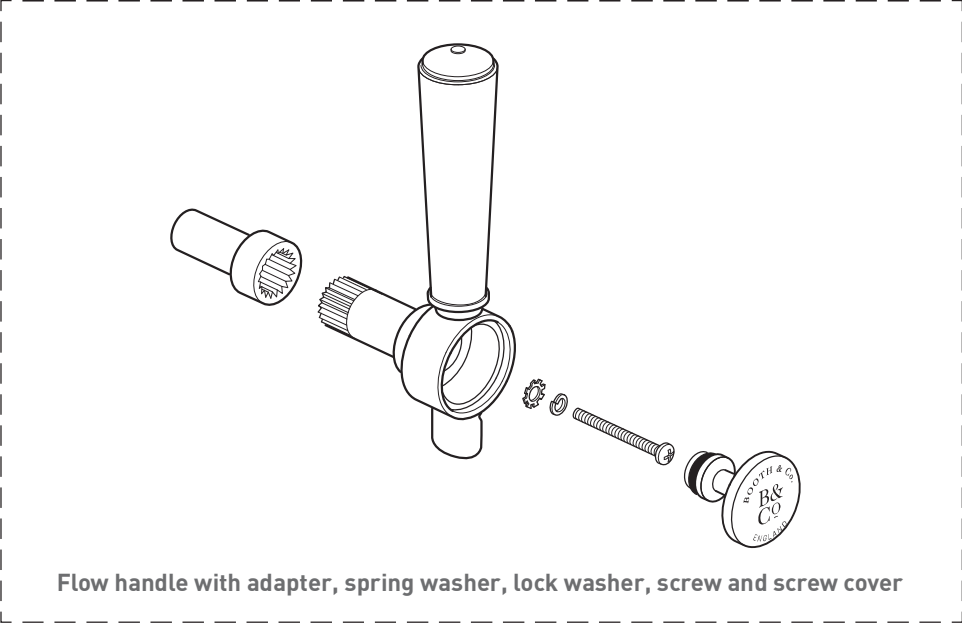

Dimensions

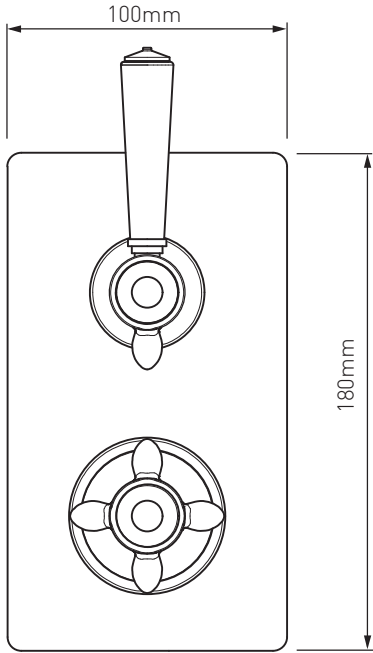
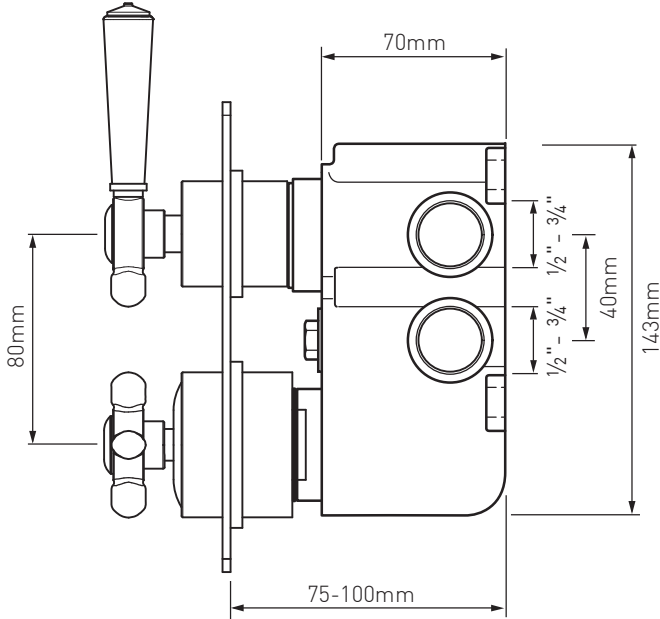

Installation - Quick guide

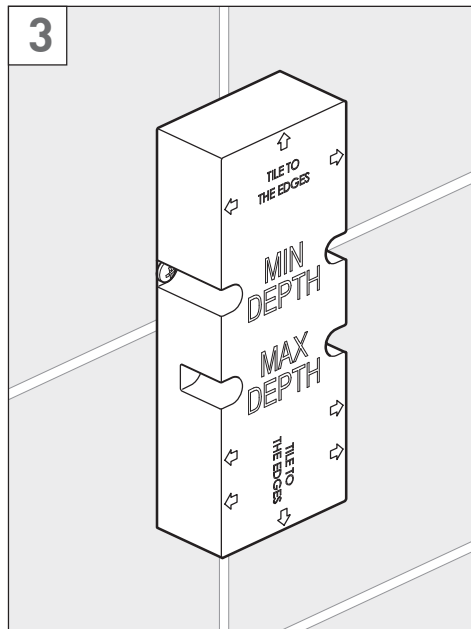
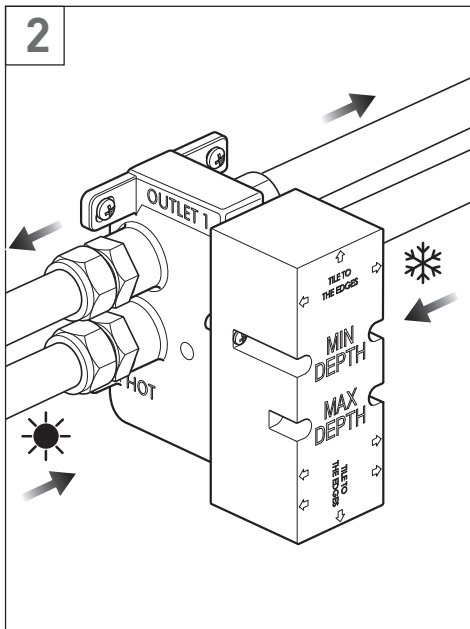
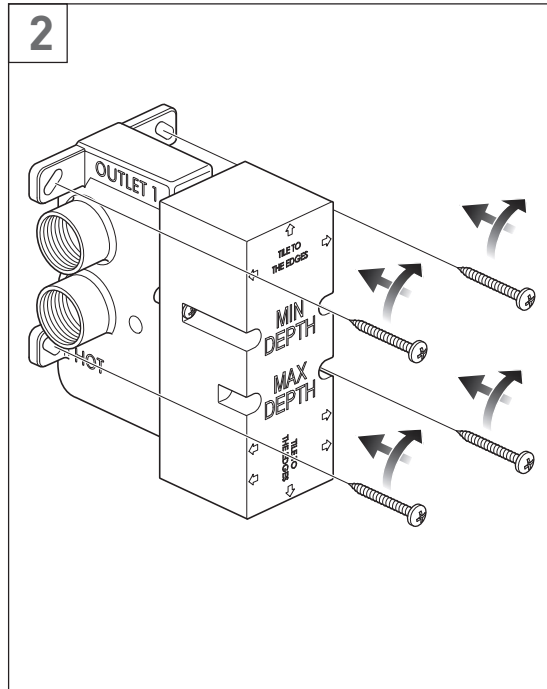
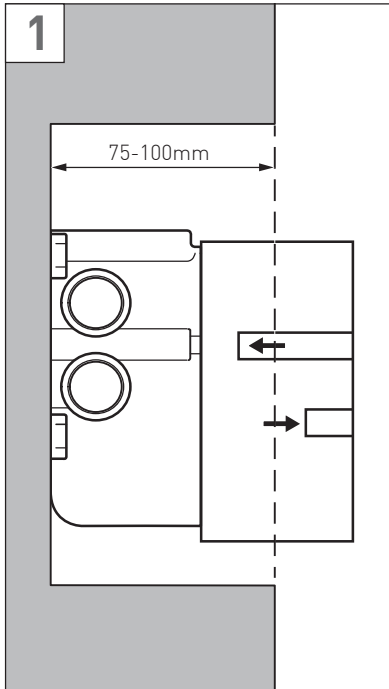

Installation - Quick guide

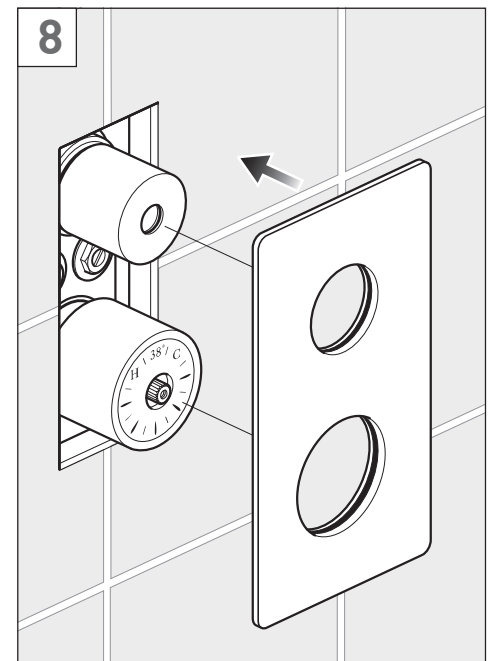
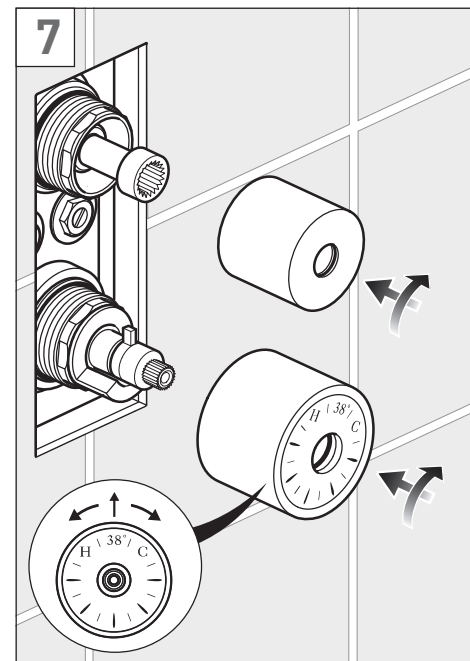
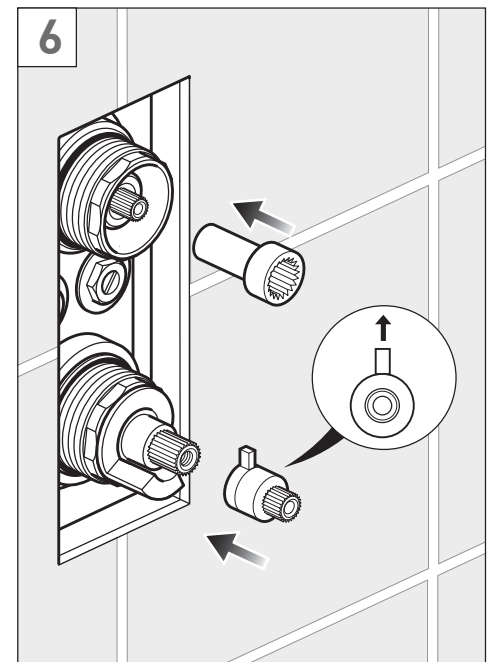
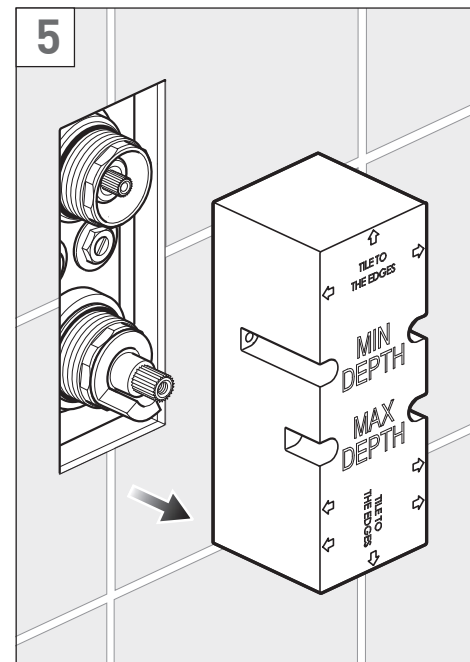

Installation - Quick guide

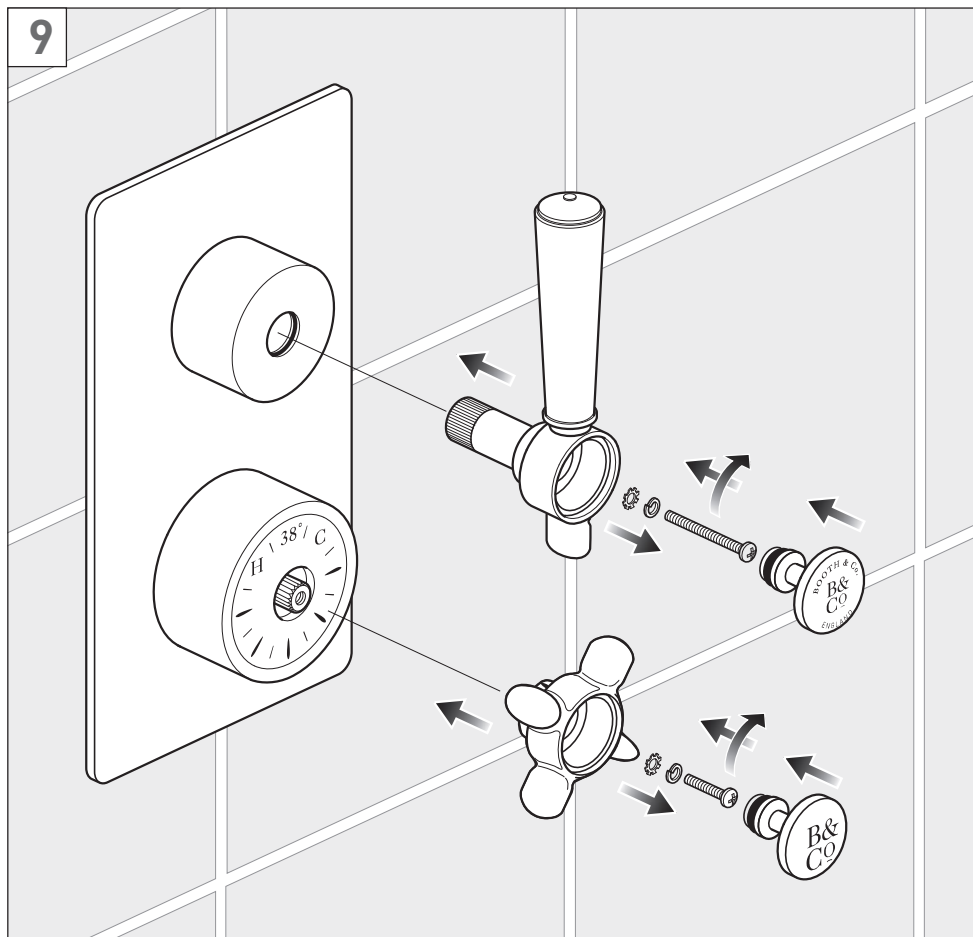

Installation

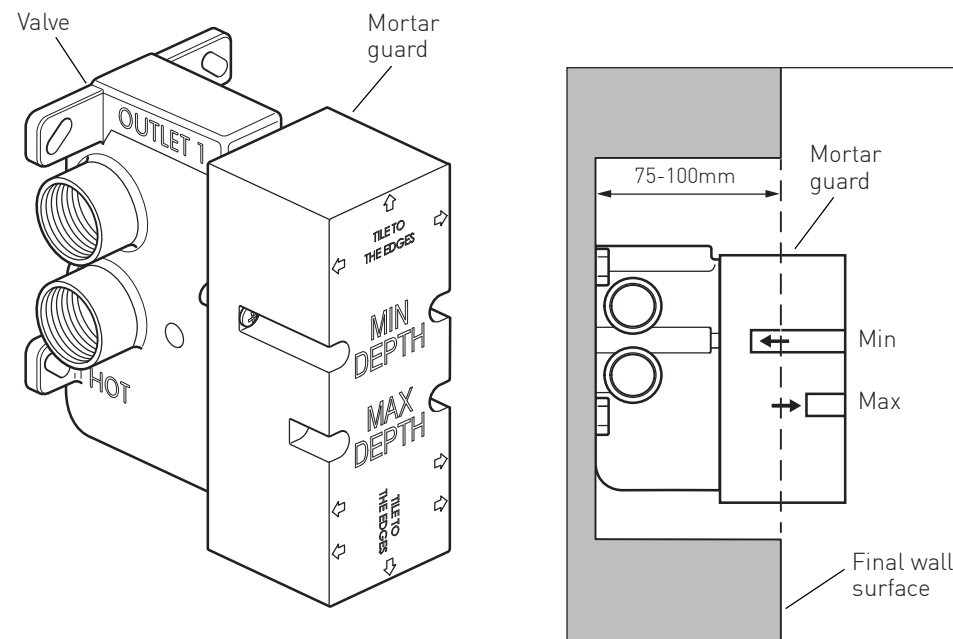

Flush pipe work thoroughly before fitting the valve.

Warning! Please check for any hidden cables and pipes before drilling holes in the wall.

The valve must be set into the wall between (75mm minimum – 100mm maximum). If you are fitting the valve to a partition wall or a wall of particularly soft substrate you will need specialist fixings.

Mortar guard

During and after installation protect the outer parts by leaving the mortar guard on the valve.

Installation

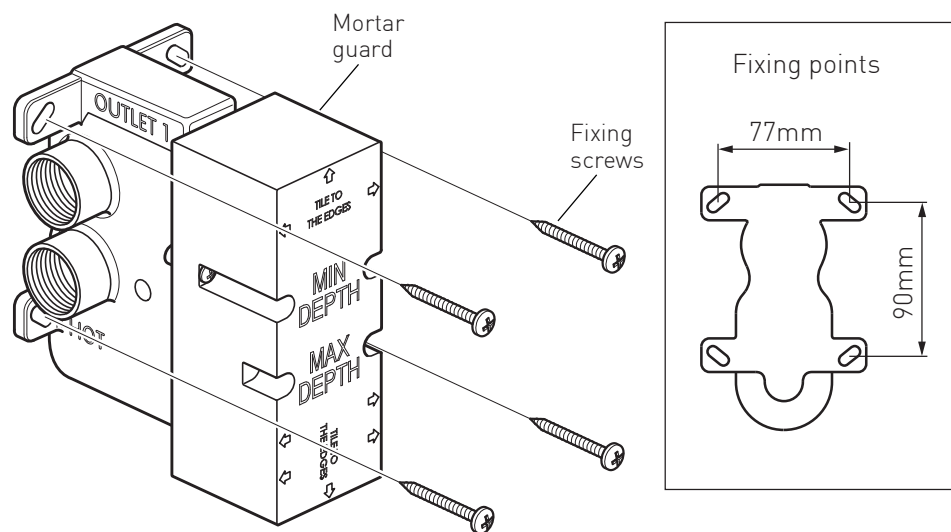

Select the position for the shower valve and offer the shower valve to the wall, make sure the valve is vertical with a level and suitably mark the fixing points, see above right for dimensions.

Remove the shower valve from the wall, drill the holes to a suitable depth for the wall plugs and secure with suitable screws.

Connect hot supply to the left inlet of the valve and cold supply to the right inlet.

Connect the outlets to the desired channels e.g. outlet 1 to the shower and outlet 2 to the handset etc.

Finish the wall by tiling up to the mortar guard, keep the final finished wall surface between the min and max marks. Illustration right shown with tiles in the minimum position.

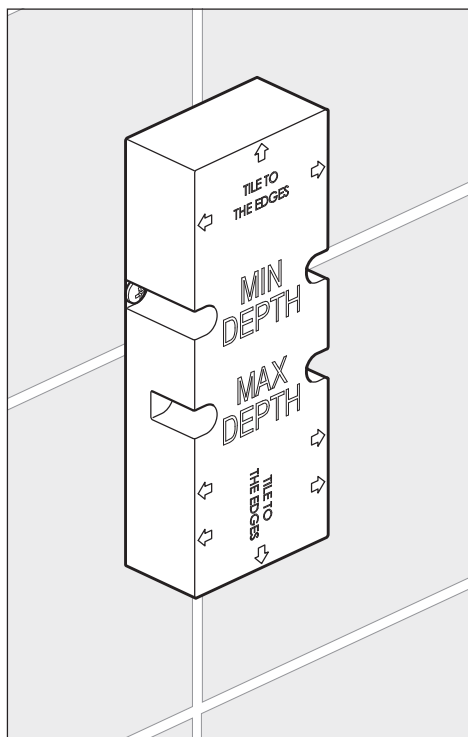

Installation

Unscrew the two mortar guard screws and remove from the wall.

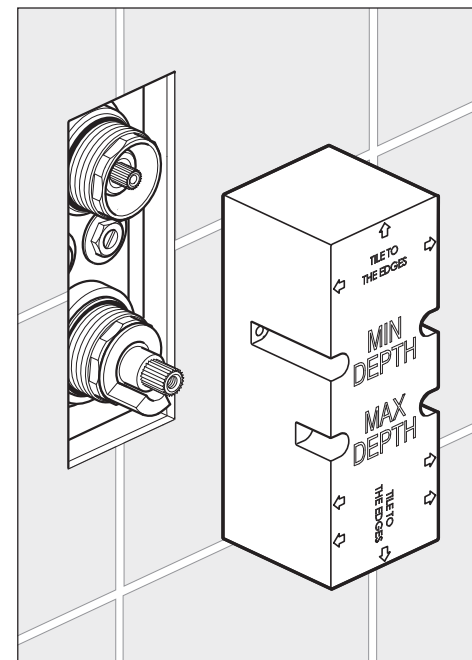

Carefully slide the flow adapter onto the splines.

Carefully slide the temperature stop arm onto the thermostatic cartridge with the stop arm located at 12 o'clock. Be careful not to turn the splines of the valve.

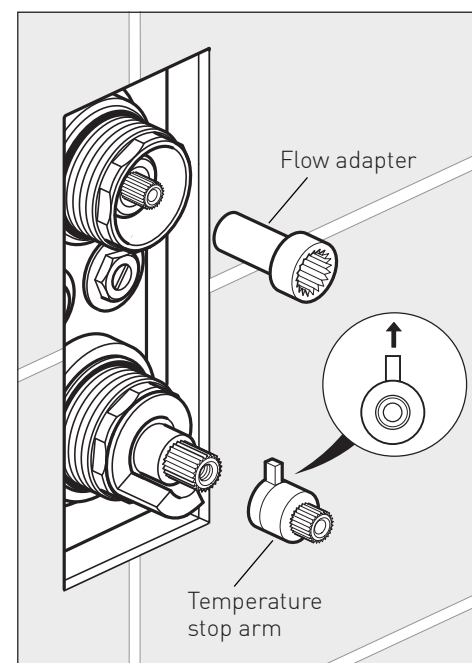

Installation

Screw the shrouds into position (hand tight only).

Make sure that the temperature shroud is fully screwed in, then unwind until the 38° mark is at 12 o'clock.

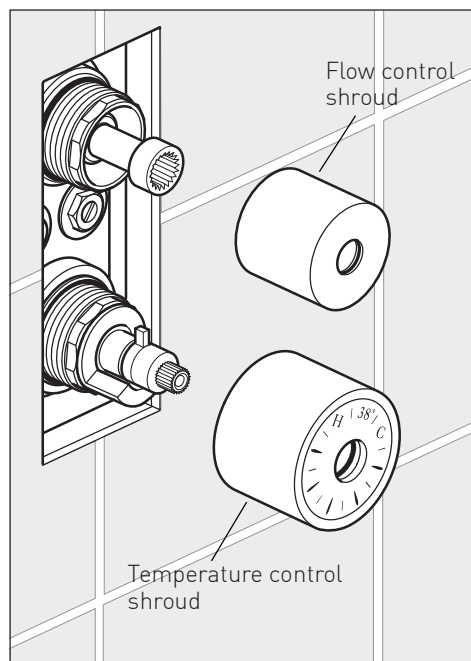
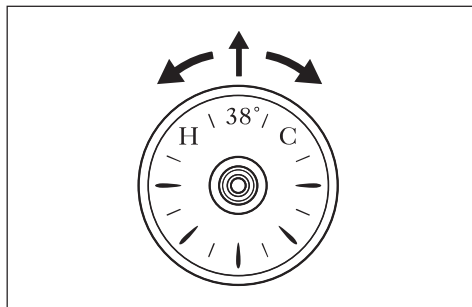

Slide the cover onto the shrouds.

If the valve is sited within in a wet environment, it is recommended that once the valve is commissioned (see page 15) the cover is sealed with a thin bead of sealant around three sides to provide a water-tight seal between the plate and the wall material, leaving the bottom edge free to allow for maintenance purposes.

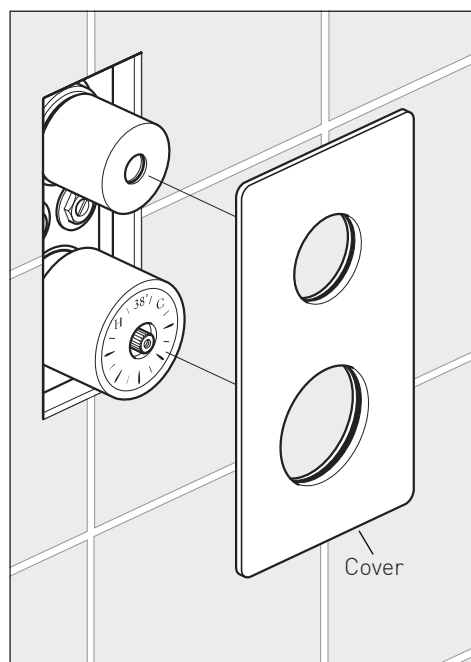

Installation

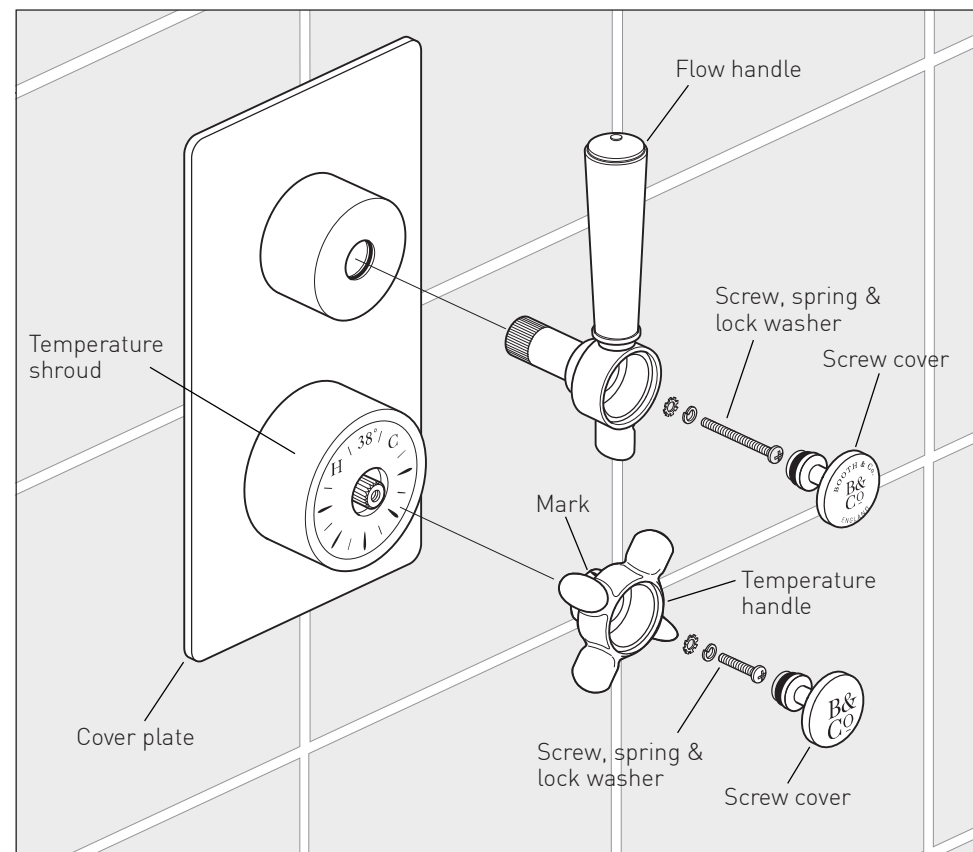

Flow handle (top)

Carefully slide the handle onto the splines of the valve, the lever should be in the 12 o'clock position.

Secure in position using the lock washer and screw, push on the ceramic screw cover.

Temperature handle (bottom)

Line up the mark on the handle with the 38° mark on the shroud. Carefully slide the handle onto the splines of the valve. Secure the handle in position using the lock washer and screw, push on the ceramic screw cover.

DO NOT try to unscrew the temperature shroud once the handle has been screwed into place as this could damage the ceramic.

Commissioning

The valve has been factory set under balanced pressures and hot supply at 65°C. When your specific operating conditions are significantly different from the above, the temperature of the delivered water may vary from the setting.

When the difference is too great, you can adjust the calibration of the valve to suit individual requirements of the installation.

Note: mixed water temperature at the terminal fitting should not exceed 46°C.

With the handle and temperature shroud removed, check the temperature of the water being delivered from the outlet with a thermometer, when the stop arm is located at 12 o'clock (**fig 1**).

Note: temperature readings should be taken at normal flow rate after allowing the system to stabilize.

If the temperature is not 38°C proceed to commission the valve as follows.

Remove the stop arm (**fig 2**).

Ensure the step on the stop ring is located at 8 o'clock (**fig 3**).

Rotate the spline of the thermostatic cartridge clockwise to decrease and anti-clockwise to increase the temperature until 38°C is achieved at the outlet.

Note: the sensing part of the thermometer probe must be fully submerged in the water that is to be tested.

Carefully replace the stop arm with the stop arm located at 12 o'clock (**fig 1**) without turning the spline of the thermostatic cartridge.

Replace the temperature shroud and handle (following the same procedure as illustrated on page 8 and 9).

Ensure the water temperature does not exceed 46°C when turned entirely anti-clockwise.

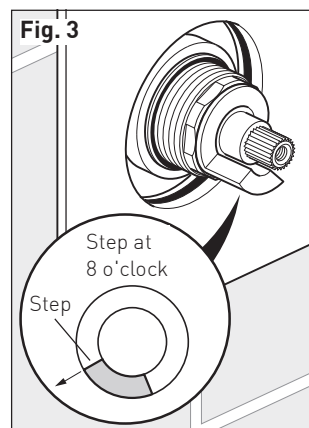
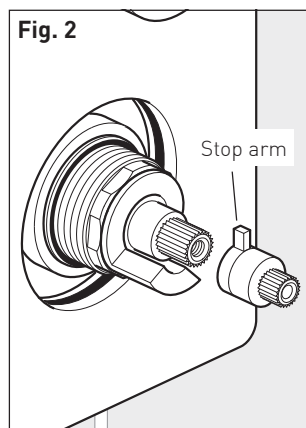
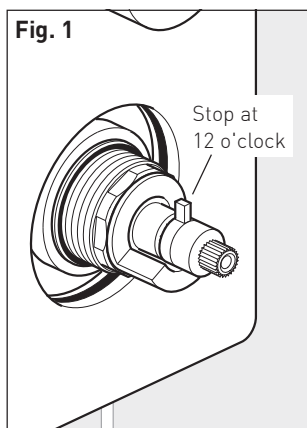

Maintenance

We advise that the below is carried out annually as failure to do so may result in invalidation of warranty.

Isolate the water supply to both hot and cold inlets, before commencing any maintenance work below.

IMPORTANT:

Please see the below procedure for isolating concealed thermostatic valves.

1. Remove handles (reverse the procedure shown on page 13) faceplate and temperature trim parts allowing access to the isolation points on the valve.

2. Screw down the isolation screws clockwise until you feel a resistance (taking care not to over tighten) (**fig 1**).

3. Turn the flow handle on to check isolation, please ensure that your body/hands are not under the flow of water as there is a potential for delivery of hot water.

4. Remove temperature arm and stop ring (essential) (**fig 2**).

5. With shower flow handle in the on position, replace temperature stop arm and handle on thermostatic valve (ensure temperature stop ring has been removed).

6. Turn temperature handle fully anti-clockwise until stop point is reached and can be turned no further, please ensure that your body/hands are not under the flow of water as there is potential for delivery of hot water if isolation has been unsuccessful.

7. Turn temperature handle fully clockwise until you feel a click.

8. If there is no flow of water coming from the outlet during both points 6 and 7 isolation has been successful, you may now remove and maintain the cartridge.

9. If at any of the above points water continues to flow please isolate at an alternative point within the system for both hot and cold and repeat points 3-9.

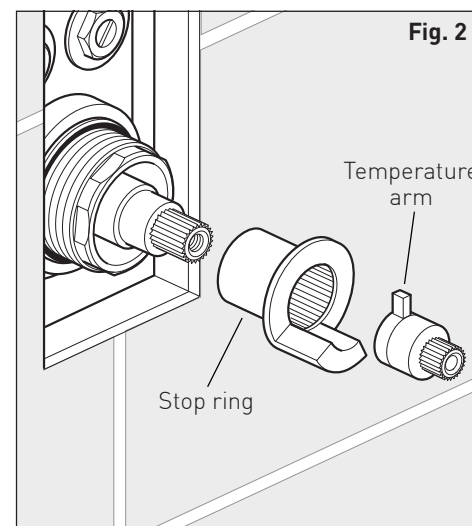
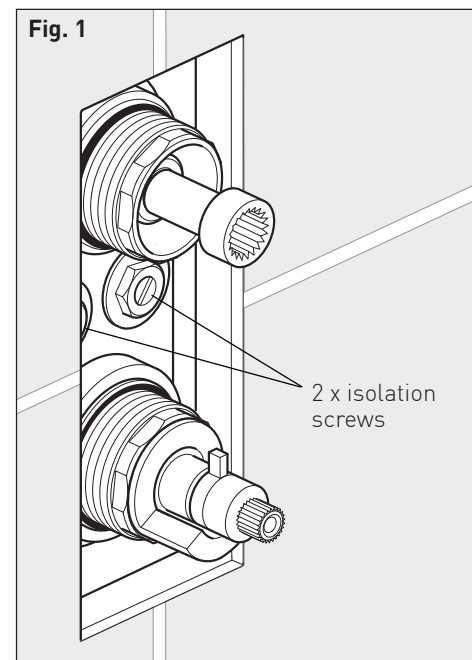

Maintenance

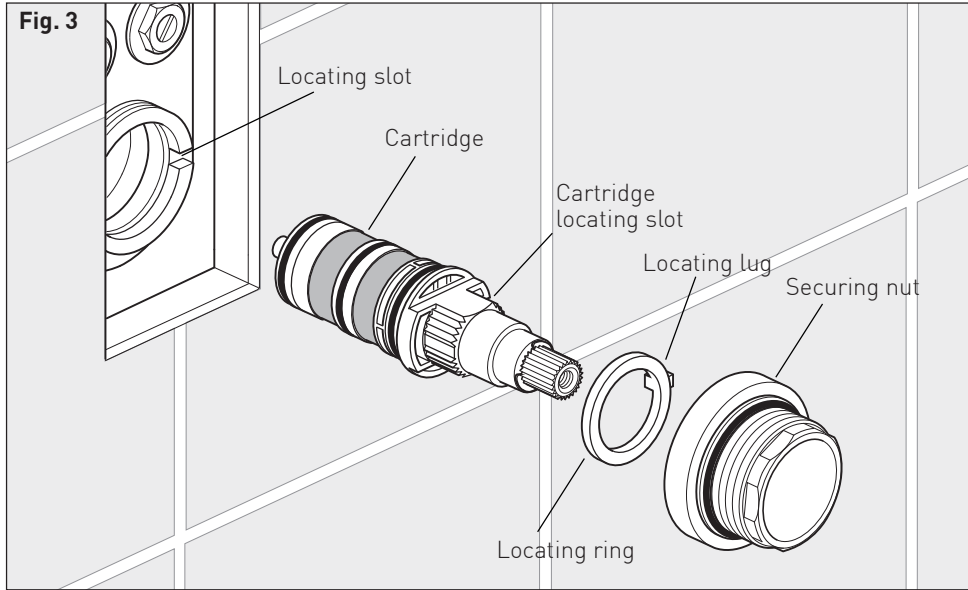

10. Using a suitable spanner, unscrew and remove the valve securing nut, pull out the locating ring and pull out the thermostatic cartridge (**fig 3**).

Note: Ensure care is taken as a small amount of residual water may escape when removing the cartridge.

11. Clean the cartridge filters by rinsing them under running water to remove any debris.

12. If there is limescale deposits then it is recommended to immerse the cartridge for a few minutes in 50% white vinegar + 50% hot water, brush the filters gently and then rinse under running water to clean all particles. If this is not effective, a replacement cartridge should be fitted.

13. Before reassembling the cartridge, clean its housing with a wet cloth and grease the O-rings using a suitable silicone grease (**fig 4**). Insert the thermostatic cartridge into the body aligning the slot in the body with the location slot in the cartridge.

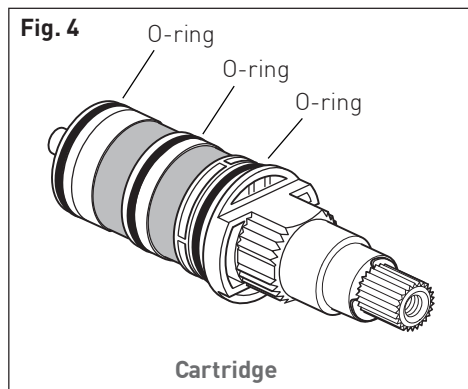

Maintenance

14. Replace the locating ring and securing nut then tighten using a suitable spanner, careful not to overtighten.

15. Replace the temperature stop ring on the cartridge with the step located at 8 o'clock (**fig 5**), then replace the temperature arm with the stop at 12 o'clock.

16. Turn the water supply on by unscrewing the isolation screws on the valve body, anti-clockwise, until the isolation screws are flush with the housing nut on the valve body.

17. Check the water temperature to ensure correct commissioning. See previous section.

18. Replace the shroud, face plate and secure the handles.

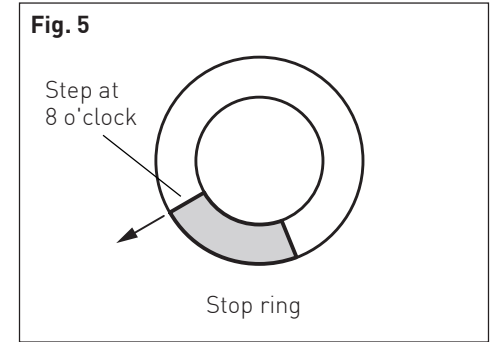

Notes

Notes