

# SPECIFICATION SHEET

COLLECTION: AXBRIDGE

PRODUCT CODE: BC-AXB-SFSRK-BN

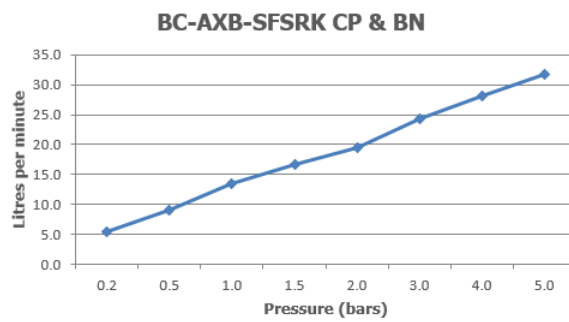

The flow rate displayed is calculated using ideal system conditions. This result should only be taken as an indication as the flow rate may vary depending on the specific in-situ configuration.

## SHOWER TYPE

Slide Rail Shower Kit

## WITH PUSH BUTTON CONTROL

No

## SELF-CLEANING

No

## WITH HOSE RETAINER

No

## WITH CROSS-SPRAY TECHNOLOGY

No

## RUB-CLEAN NOZZLES

No

## ADJUSTABLE FIXING FOR EASY RETRO FIT

No

## WITH AIR-INJECTION TECHNOLOGY

No

## WITH TWIST CONTROL

No

tel: 01934 744466  
email: sales@vado.com  
www.vado.com

WHERE INSPIRATION FLOWS  
TAPS | SHOWERS | ACCESSORIES



# SPECIFICATION SHEET

COLLECTION: AXBRIDGE  
PRODUCT CODE: BC-AXB-SFSRK-BN

## HOSE

with 150cm hose

## STYLE

Traditional

## MOUNTING

Wall Mounted

## PLUMBING SYSTEM SUITABILITY

Gravity System, Pumped System, Combination Boiler, Pressurised System

## COLLECTION NAME

Axbridge

## FINISH

Bright Nickel

## MINIMUM OPERATING PRESSURE

0.2 Bar LP

## MAXIMUM OPERATING PRESSURE

5.0 Bar HP

## GUARANTEE

15 Year Guarantee



# TECHNICAL DRAWING

COLLECTION: AXBRIDGE

PRODUCT CODE: BC-AXB-SFSRK-BN

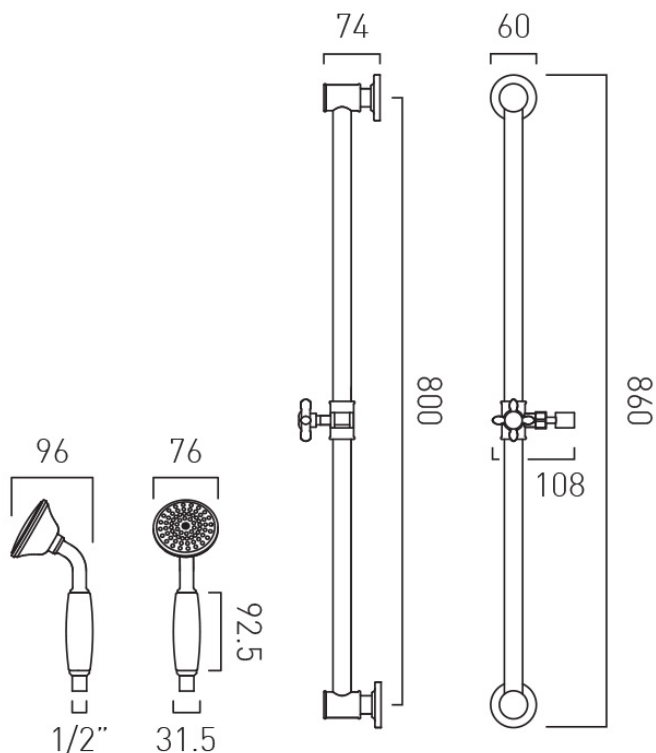

tel: 01934 744466  
email: sales@vado.com  
www.vado.com

WHERE INSPIRATION FLOWS  
TAPS | SHOWERS | ACCESSORIES

