

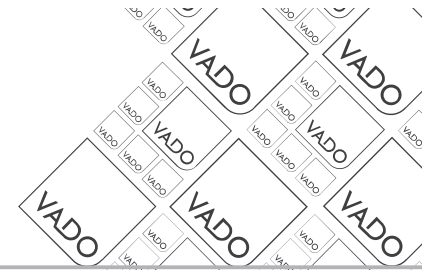

where inspiration flows

WATERGAMES



Installation Guide
Back to wall cistern cover

This instruction booklet covers these models:
CAM-FBTW

CAM-FBTW

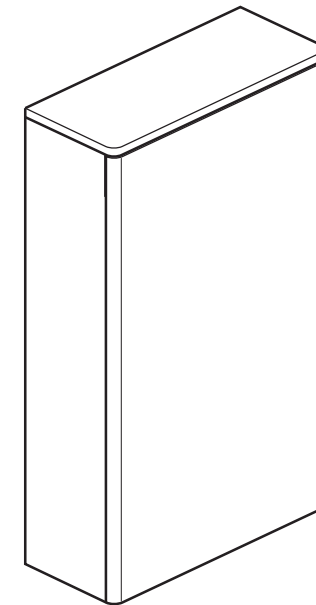

Vado
Wedmore Road, Cheddar, Somerset, England BS27 3EB
tel 01934 744466 fax 01934 744345
aftersales@vado.com
www.vado.com



Important - please read

VADO reserves the right to make technical improvements and enhance the appearance of the products included in this instruction manual.

Please read these instructions carefully before starting installation and keep for future reference.

Remove all packaging and check the product for missing parts or damage before starting installation.

Any alterations made to this product and fittings may infringe water regulations and will invalidate the guarantee.

The installation must comply with all Local/National Water Supply Authority Regulations/ Byelaws and Building and Plumbing Regulations.

To be installed in accordance with BS EN806.

We strongly recommend that you use a qualified and registered plumber.

General Care and Safety

Wall plugs supplied are ONLY suitable for solid stone/brick walls. They are not suitable for use in aerated blocks or similar. If fixing to a stud wall, sufficient extra internal reinforcements must be made to the wall. Screws must locate into suitably reinforced studs and noggins.

Take care using power tools - The use of a residual current device (RCD) is recommended. Beware of hidden cables or pipes when drilling.

This product can be dangerous if installed incorrectly. This product must be installed by a qualified plumber or installer. It is the installer's responsibility to check that the fixings are suitable for the installation in hand.

Cistern fittings are suitable for Water pressure: 0.2 - 10 bar. Do not add caustic chemical substances (eg containing chlorine compounds or similar into the cistern. These can damage the valve components and cause failure.

Before starting to enclose the frame, the system must be first tested for leaks before 2nd fix commences. Using the help of a second person to hold the pan in place on the frame, turn on the water supply and flush the pan to check for leaks.

When installed, the fitting must comply with the requirements of the Water Supply (Water Fittings) Regulations 1999 and Scottish Byelaws 2004.

For further information, contact the Water Regulations department of your local water supplier (see the WRAS website www.wras.co.uk for details) or the Water Regulations Advisory Scheme by email (info@wras.co.uk) or telephone: 01495848454.

Please take great care when installing this product not to damage its surface.

Please note if installing in an enclosed environment, access should be left for servicing and maintenance. No costs relating to inadequate access can be accepted.

Contents of packaging - Panels

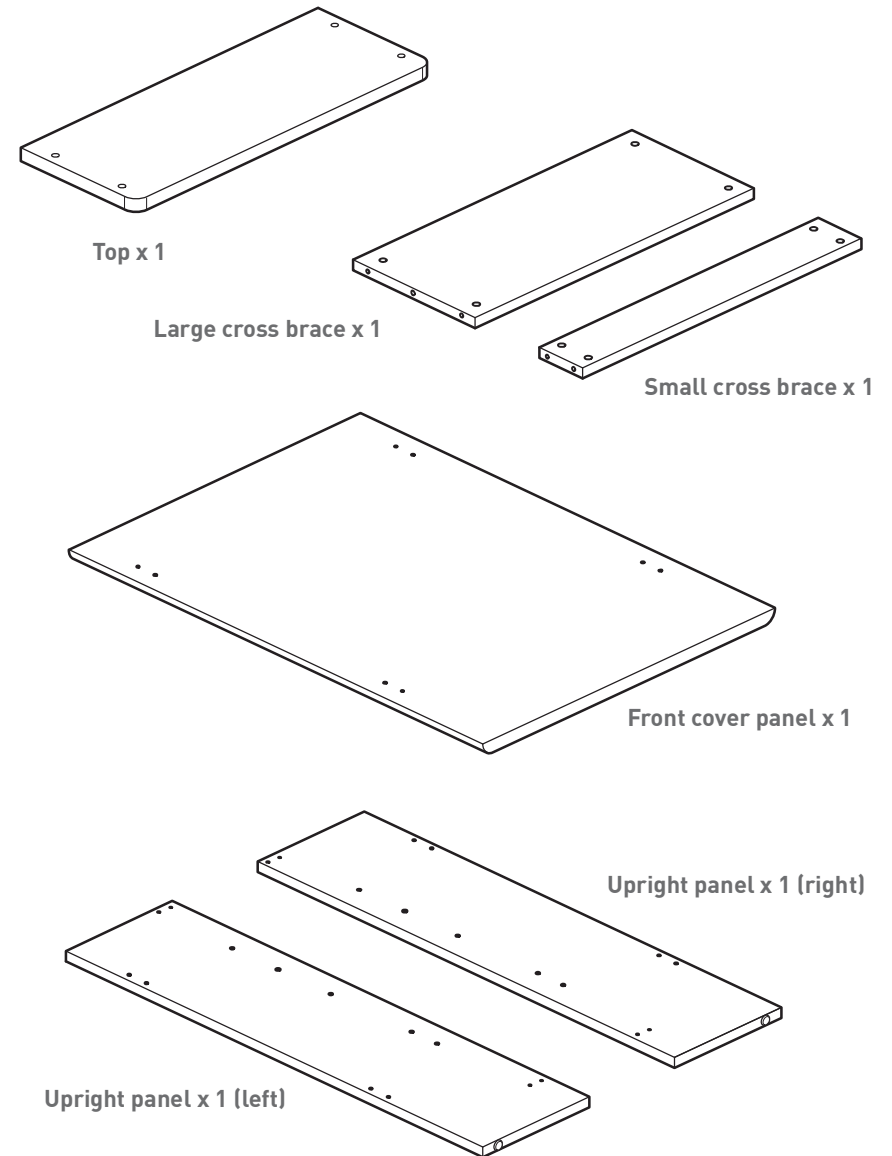

Contents of packaging - Fixings

Dimensions

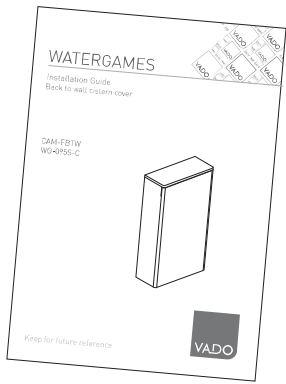

Installation guide & User manual

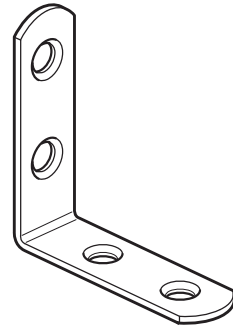

Angle brackets x 4

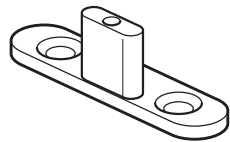

Latch x 4

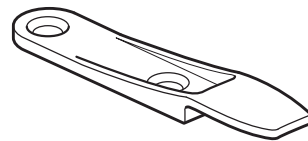

Panel clips x 4



Cams x 8



Metal dowels x 8



Wooden dowels x 6

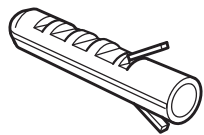

Wall plugs x 8

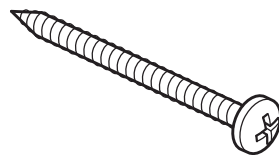

Screws x 8

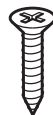

Screws x 24

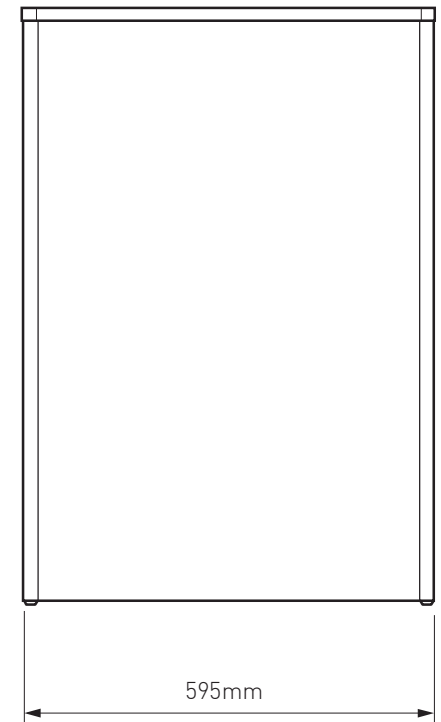
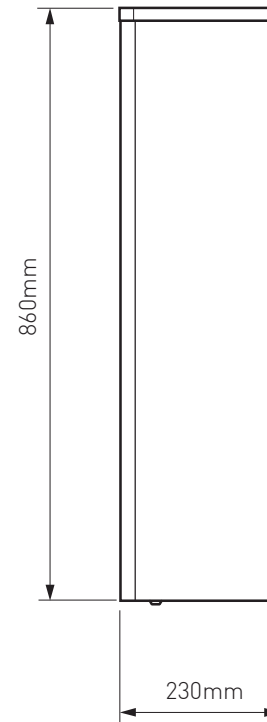
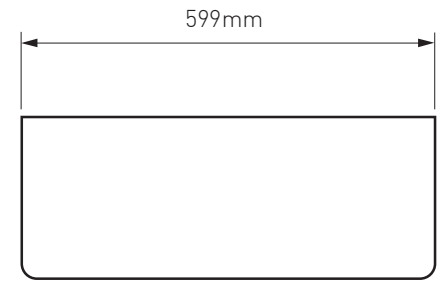

Installation

1

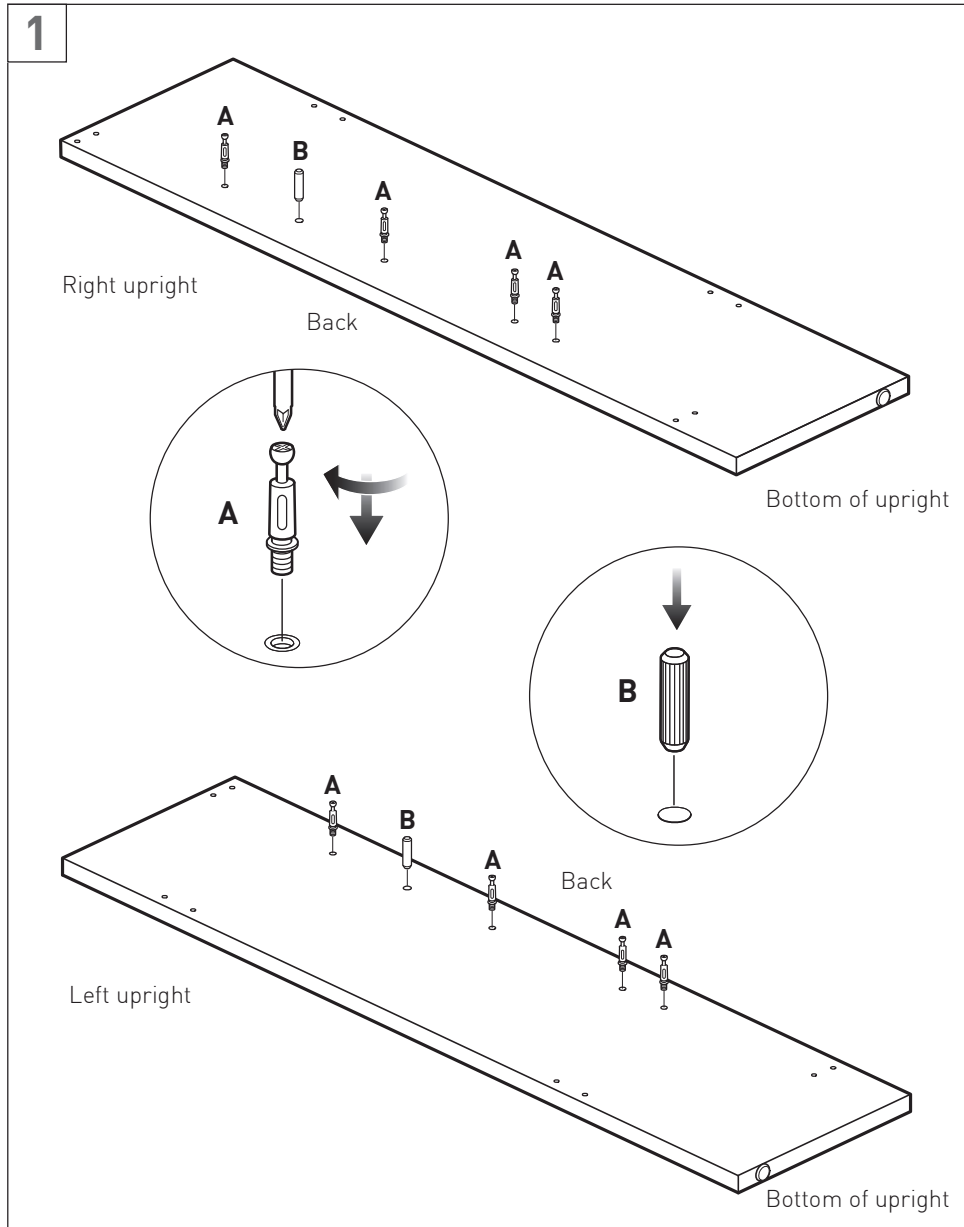

In each side panel screw in the four metal dowels **(A)** along the back of the panel. Push the wooden dowel into the hole **(B)** you might need to lightly use a rubber hammer to make sure its home.

Installation

2

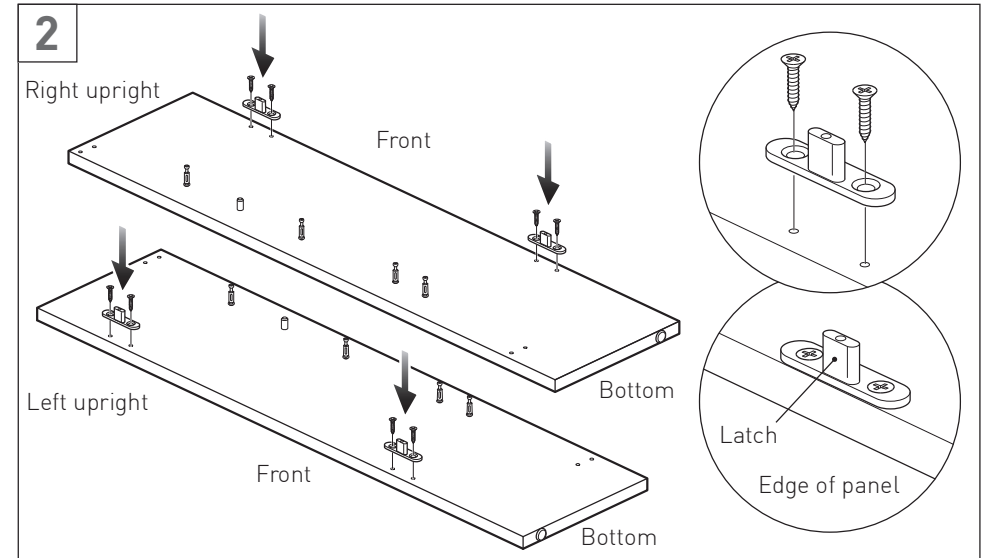

Screw the four latches in place along the front edge of the panel using the small screws into the pre-drilled holes. Make sure the latch is flush with the outside of the panel.

3

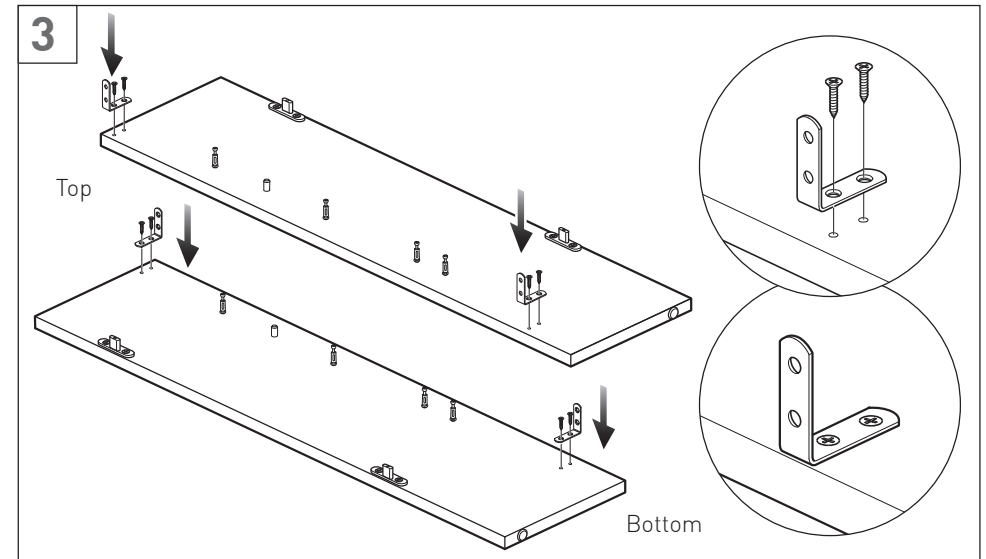

Screw the four wall brackets in position using the small screws into the pre-drilled holes. The bottom brackets are set back from the bottom of the panel.

Installation

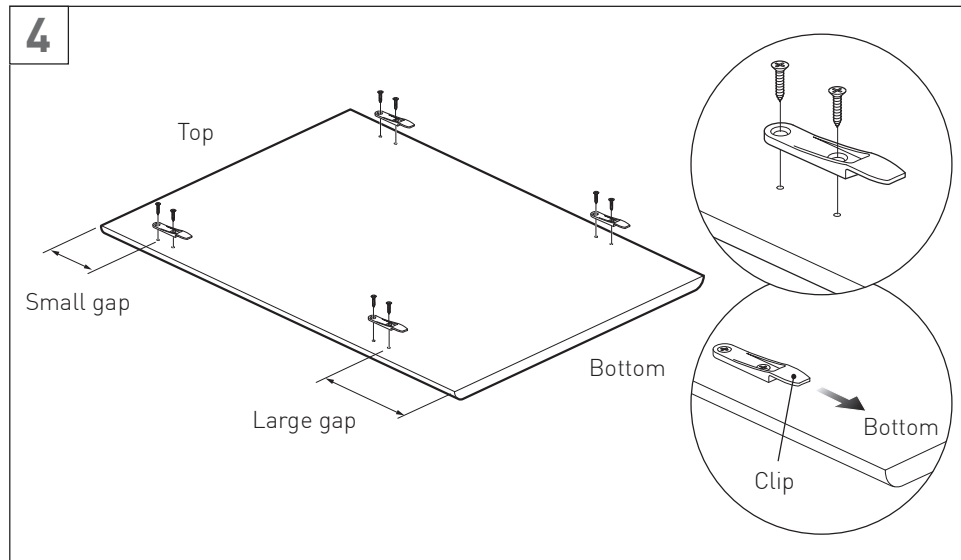

Screw the four panel clips in position using the small screws into the pre-drilled holes. The gap at the top of the panel to the clip is smaller than at the bottom. Make sure that the clip part is facing downwards.

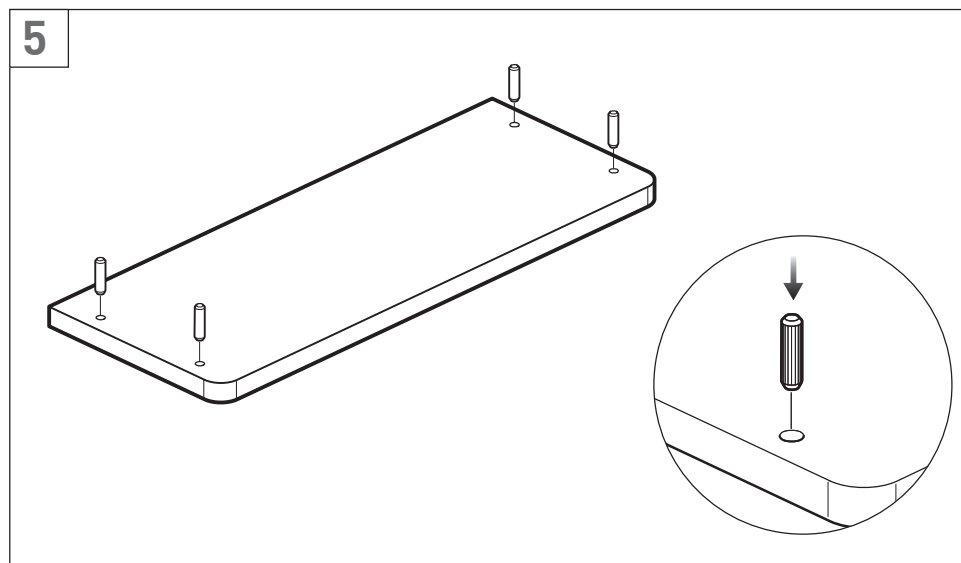

Push in the four wooden dowels into the holes in the bottom of the top. You might need to lightly use a rubber hammer to make sure they are home.

Installation

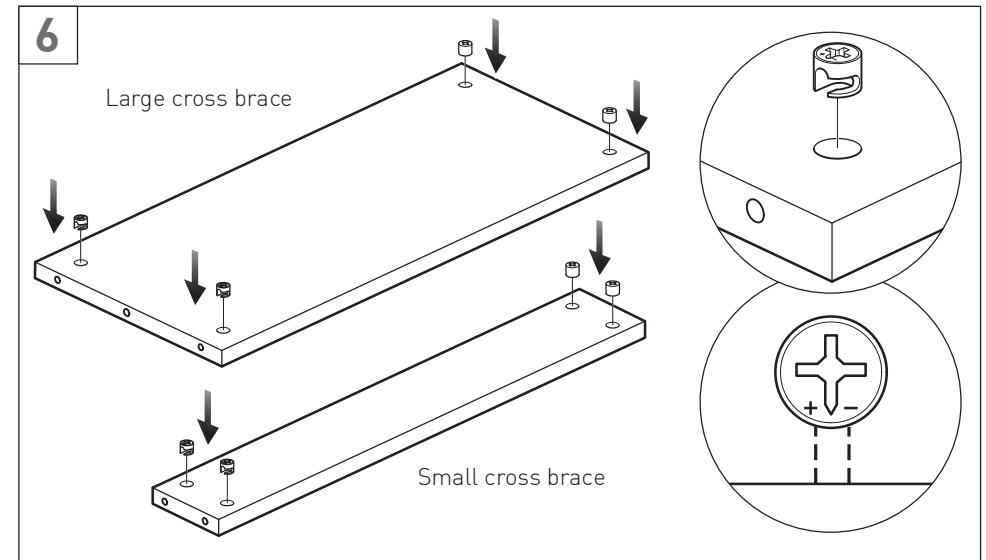

On both the large and small cross braces fit the four cams. Make sure that the arrow on the top of the cam is pointing towards the edge of the panel and the hole.

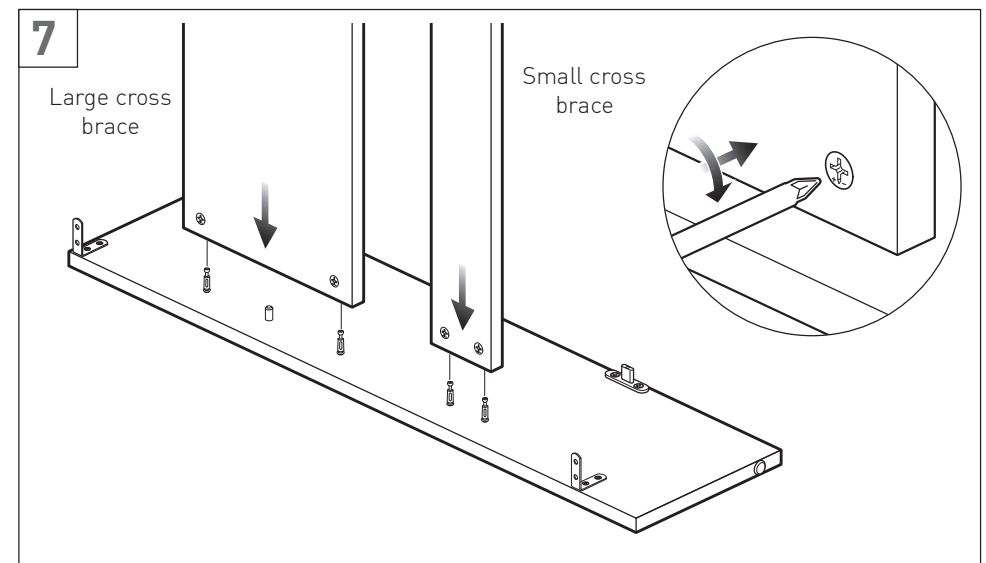

Push each of the cross braces over the dowels. With a screwdriver tighten each cam clockwise to lock the panels together. With help, stand the unit upright and push the other side panel onto the cross braces, tighten the cams.

Installation

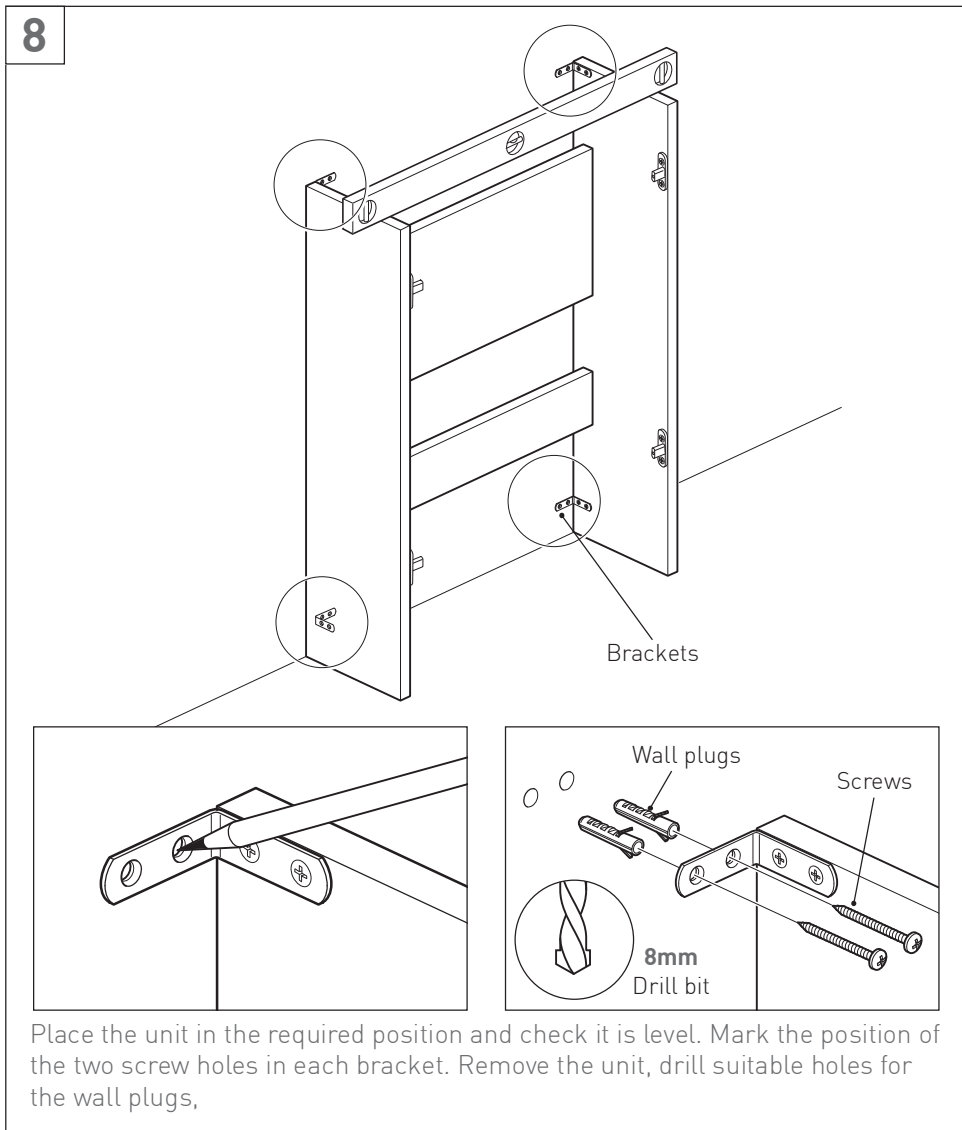

Continue the installation for your product:
For WG-095-C (new version) continue on page 11
For WG-095S-F/C Short frame & cistern continue on page 14

Installation - WG-095S New version

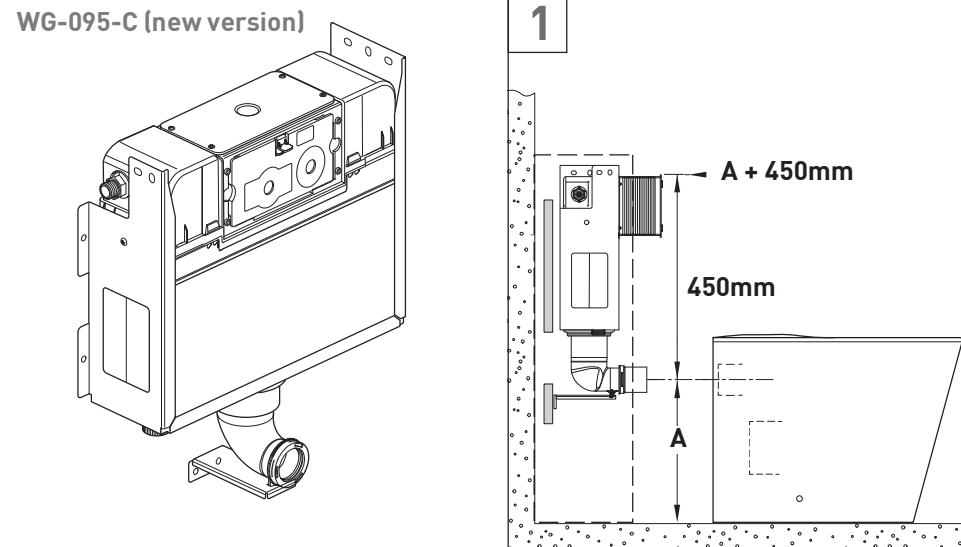

Measure the height at the centre of the toilet inlet (**A**). Add this to give you height to the top of the box.

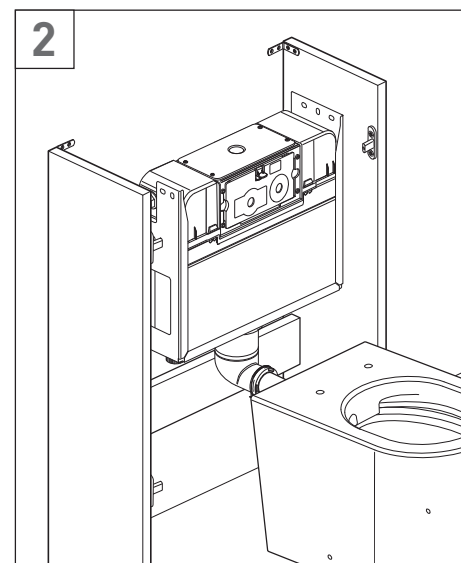

Before installing the cistern, ensure that it will fit properly inside the furniture unit at the required height.

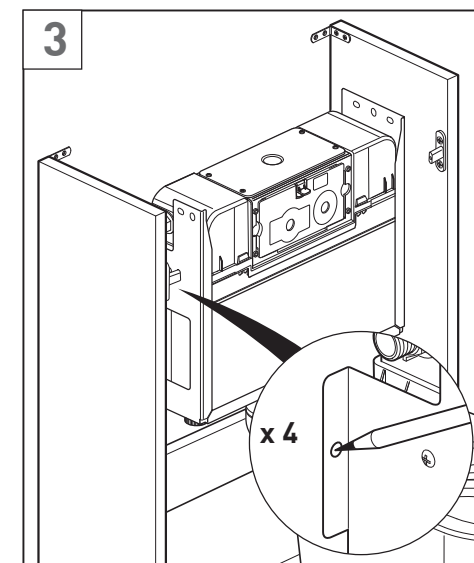

Mark the position of the four fixing holes onto the large brace.

Installation - WG-095S New version

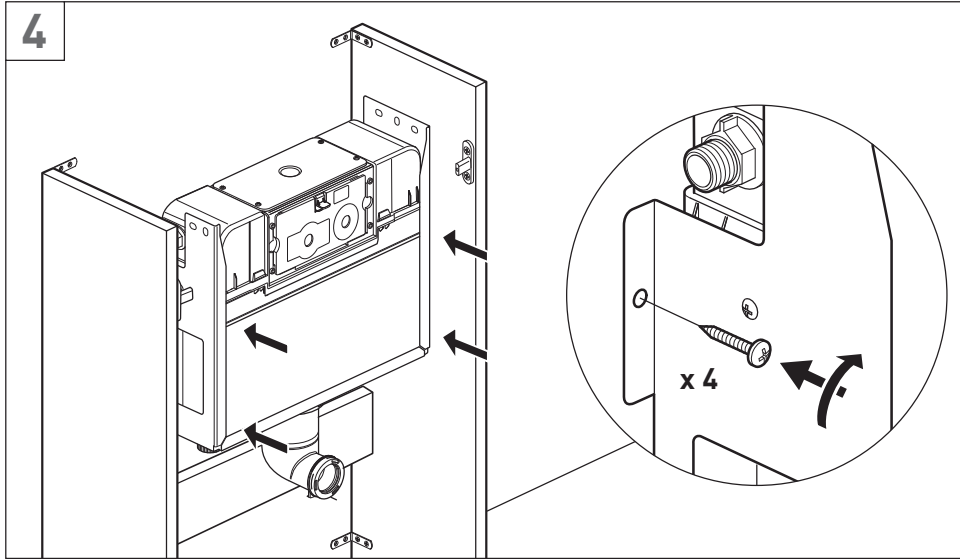

Secure the cistern in position using four suitable screws (not supplied).

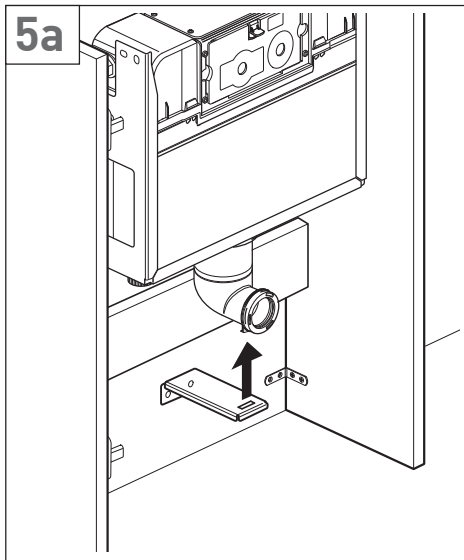

Hold the bracket slot in the bottom of the outlet bend.

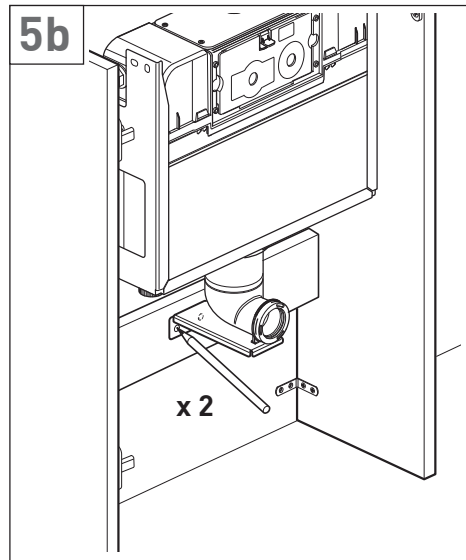

Make sure the bracket is level and mark the two holes.

Installation - WG-095S New version

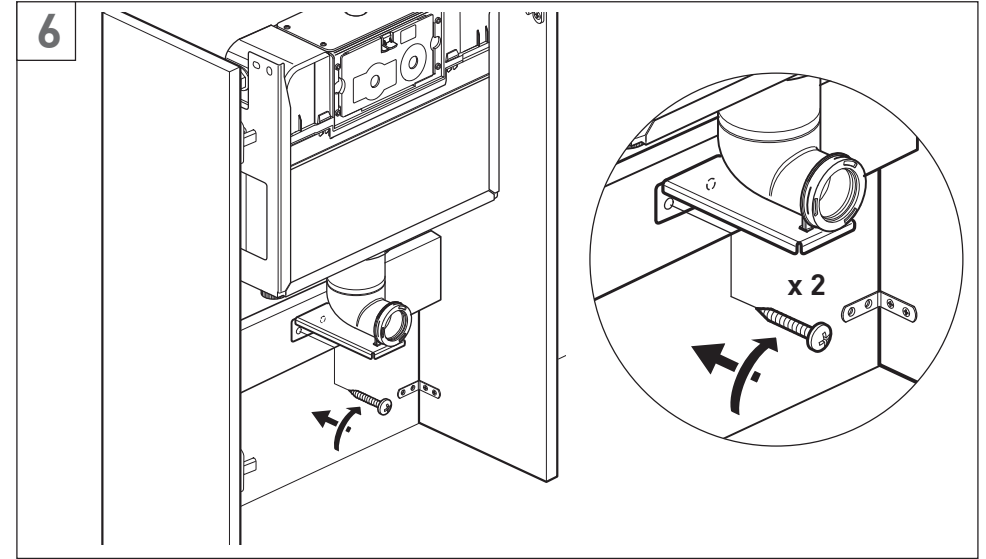

Secure the bracket to the small brace using two suitable screws (not supplied).

**Continue your installation using
the original instructions
supplied with the cistern.
Starting from step 4.**

Installation - Short framed with front mounted flush plate

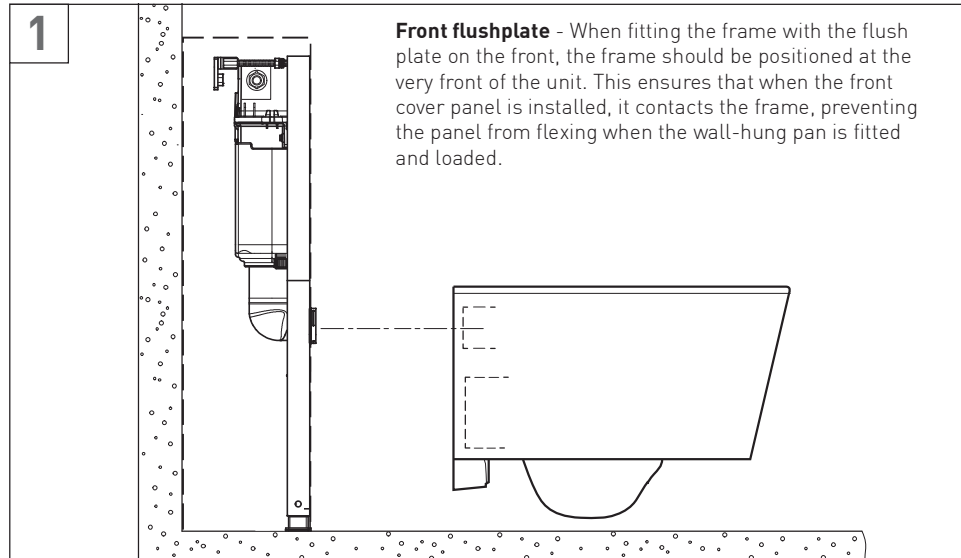

The two cross braces are not required for this configuration. It may be necessary to stand the frame off the wall to enable the flush plate to be front fitted (by more than the supplied wall brackets allow).

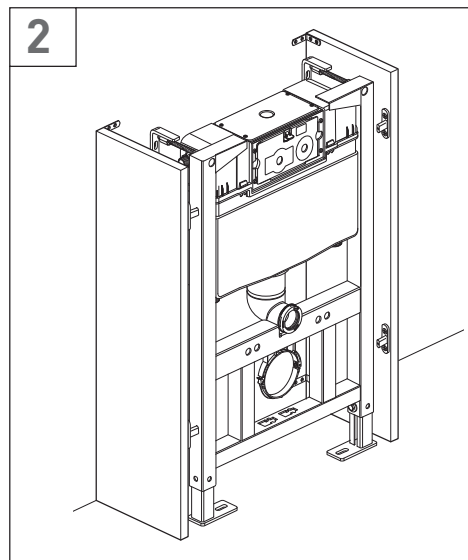

Position the frame flush with panel sides.

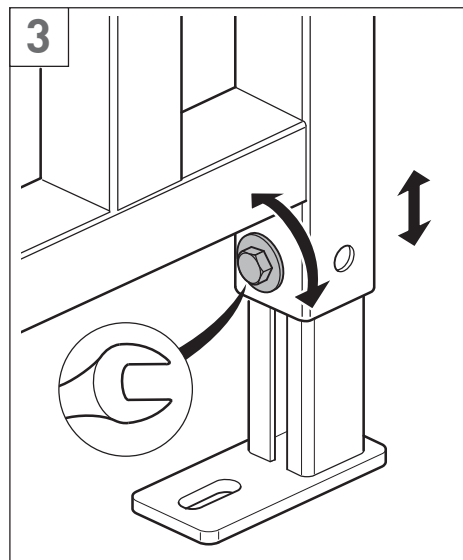

Release the nut to adjust the height of the frame. When in the required position retighten the nut.

Installation - Short framed with front mounted flush plate

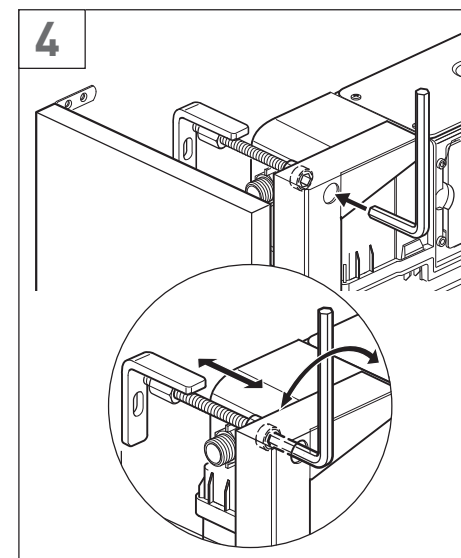

Locate the hex key hole in the corner of the frame. Turn anti-clockwise to undo the bracket to its maximum position.

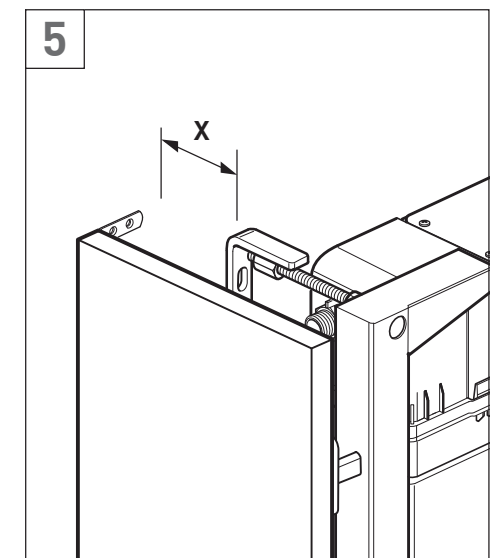

Measure the distance **X** from the back of the bracket to the wall.

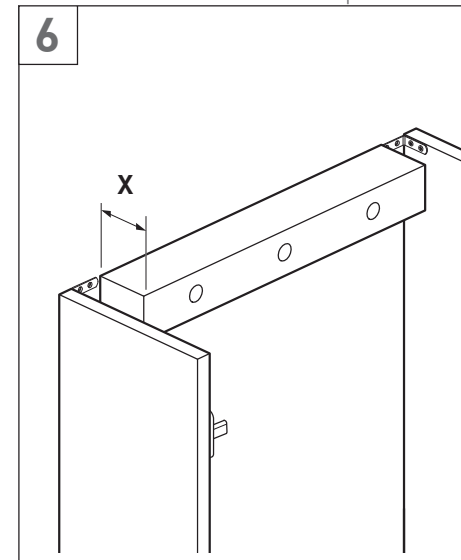

Screw a batten (**X** wide) to the wall level with the sides. Use suitable coach bolts for your wall (not supplied).

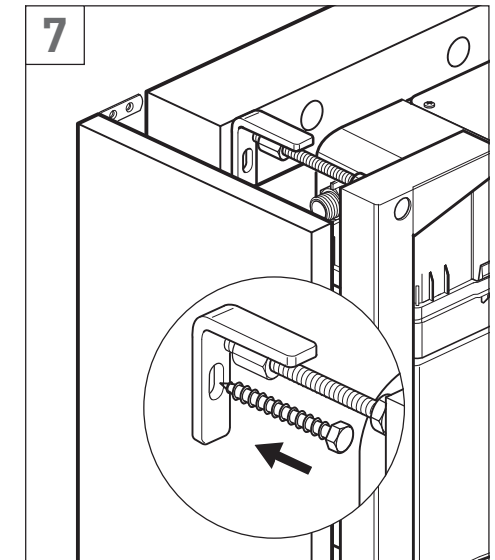

Secure the frame to the batten using the supplied coach bolts. Rotate the brackets to point inwards if required.

Installation - Short framed with top mounted flush plate

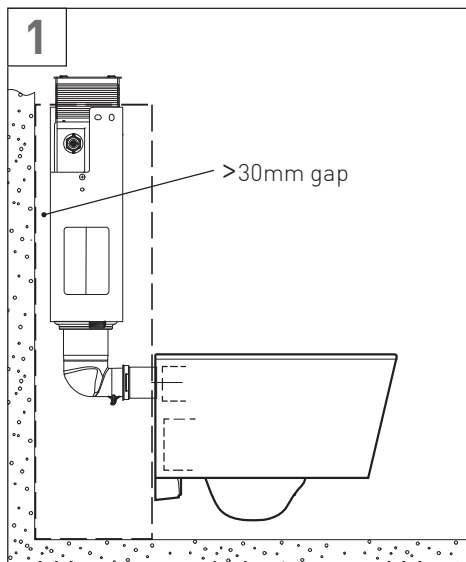

Install the frame making sure there is at least a 30mm gap between the cistern and the wall.

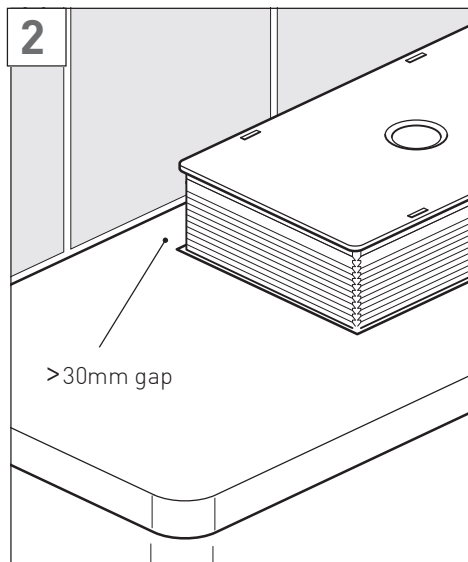

Make sure there is gap of at least 30mm between the finished wall and the face plate box.

Continue your installation using the original instructions supplied with the cistern. Starting from step 6.

Guarantee

This VADO WC Cover comes with a 2-year guarantee as standard. Within this guarantee period, VADO will provide replacement parts.

This standard guarantee may be extended by registering your product on our website at: <https://www.vado.com/support/guarantee>. Once registered this vanity unit will have a 6 year guarantee.

Guarantee Conditions

Our products are guaranteed against manufacturing defects from the date of purchase until the expiry of the relevant guarantee period shown above.

The guarantee is only valid if:

- The product has been installed, used and maintained in accordance with VADO's instructions and subjected to normal use only.
- The defect is not due to accident, misuse, neglect, or incorrect/inappropriate repair (other than by VADO or VADO authorised agents) or damage caused by foreign objects or substances.

- The extended guarantee is only available if you have completed the guarantee registration process.

This can be done via the VADO website or via telephone to our Aftersales team.

Registration must be completed within 6 months from the date of purchase. Under the extended guarantee period VADO will, at its option, offer to supply any replacement product (or component part) assessed to be defective **[SEE NOTE 1]**.

- The guarantee (whether standard or extended) is non-transferable to any subsequent owner.
- Mould, Mildew build up, the effects of limescale and corrosion are not covered under this guarantee.
- This guarantee does not cover damage and/or malfunction caused by inappropriate cleaning (please refer to our recommended care and maintenance guidelines).
- Damage to VADO furniture caused by standing water or inadequate room ventilation is not cover under this guarantee.

All claims under the guarantee should be notified in the first instance to our Aftersales department, contact details below, this must be done no later than the last day of the relevant guarantee period.

All claims must be accompanied by proof of purchase (sales receipt or delivery note) from an official VADO dealer.

The guarantee does not extend to any consequential loss or damage.

After repair or replacement, the relevant guarantee period will be calculated from the original date of purchase.

VADO operates a policy of continuous product development and therefore reserves the right to change the product, packaging and documentation specifications without notice.

In situations where like-for-like replacements are not possible, VADO will endeavour to provide the closest alternative. E&OE.

NOTES:

[1] VADO reserves the right to charge in advance for a product (or replacement part) pending collection and investigation (at VADO expense) to confirm a defect is due to a manufacturing issue.

If a defect is found the charge will be refunded or cancelled.

This guarantee is in addition to and does not affect your statutory rights as a consumer.

Tel: 01934 745163

Email: aftersales@vado.com

Notes:

Notes: