

SPECIFICATION SHEET

COLLECTION: LIFE

PRODUCT CODE: LIF-200/CC-CP

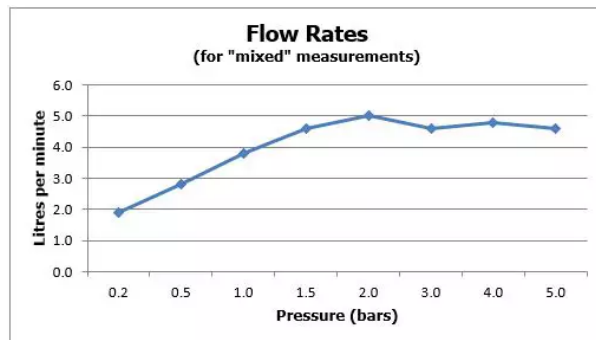

The flow rate displayed is calculated using ideal system conditions. This result should only be taken as an indication as the flow rate may vary depending on the specific in-situ configuration.

TAP TYPE

Basin Mixer

COLLECTION NAME

Life

FINISH

Chrome

RECOMMENDED FLOW REGULATOR

5 l/m flow regulator fitted as standard

MINIMUM OPERATING PRESSURE

1.0 Bar MP

MAXIMUM OPERATING PRESSURE

5.0 Bar HP

GUARANTEE

15 Year Guarantee

HANDLES

Single Lever

WITH ECOTURN COLD START TECHNOLOGY

No

tel: 01934 744466
email: sales@vado.com
www.vado.com

WHERE INSPIRATION FLOWS
TAPS | SHOWERS | ACCESSORIES



SPECIFICATION SHEET

COLLECTION: LIFE

PRODUCT CODE: LIF-200/CC-CP

WITH WATER FLOW STRAIGHTENER

No

WITH WATER FLOW AERATOR

Yes

CONNECTIONS / FITTINGS

2 x 1/2" 400mm flexipipe connections

SPARE PARTS

ceramic cartridge C010-N25

DECK HOLE DRILL DIAMETER

35mm

WASTE

with Universal Basin Waste

STYLE

Oval

MOUNTING

Deck Mounted

PLUMBING SYSTEM SUITABILITY

Pumped System, Combination Boiler, Pressurised System



TECHNICAL DRAWING

COLLECTION: LIFE
PRODUCT CODE: LIF-200/CC-CP

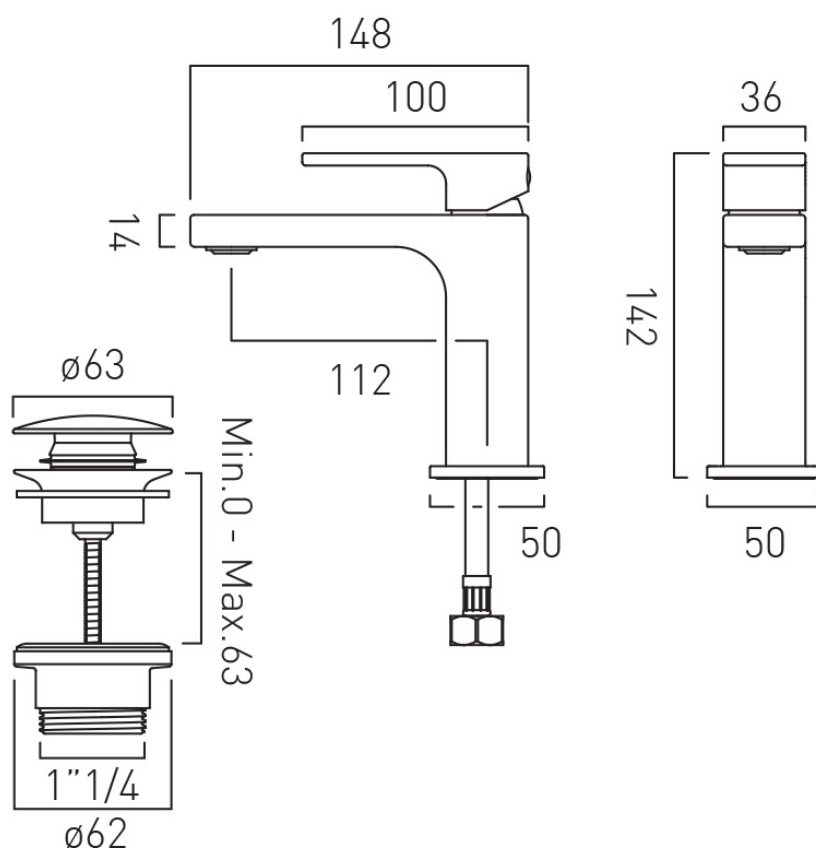

tel: 01934 744466
email: sales@vado.com
www.vado.com

WHERE INSPIRATION FLOWS
TAPS | SHOWERS | ACCESSORIES

