

SPECIFICATION SHEET

COLLECTION: ELEMENTS
PRODUCT CODE: ELW-101F-C/P

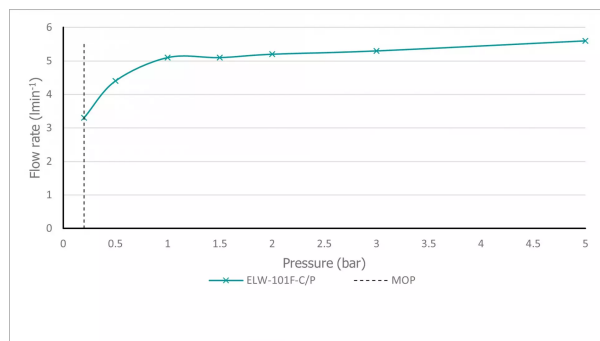

The flow rate displayed is calculated using ideal system conditions. This result should only be taken as an indication as the flow rate may vary depending on the specific in-situ configuration.

TAP TYPE

Basin Mixer

COLLECTION NAME

Elements

FINISH

Chrome

RECOMMENDED FLOW REGULATOR

5 l/m flow regulator fitted as standard

MINIMUM OPERATING PRESSURE

0.2 Bar LP

MAXIMUM OPERATING PRESSURE

5.0 Bar HP

GUARANTEE

15 Year Guarantee

WITH ECOTURN COLD START TECHNOLOGY

No

WITH WATER FLOW STRAIGHTENER

No

tel: 01934 744466
email: sales@vado.com
www.vado.com

WHERE INSPIRATION FLOWS
TAPS | SHOWERS | ACCESSORIES



SPECIFICATION SHEET

COLLECTION: ELEMENTS
PRODUCT CODE: ELW-101F-C/P

WITH SWIVEL SPOUT

With swivel spout

WITH WATER FLOW AERATOR

Yes

CONNECTIONS / FITTINGS

2 x 1/2" 600mm flexipipe connections

SPARE PARTS

cold ceramic cartridge C-206-RTC hot ceramic cartridge C-206-LTC

DECK HOLE DRILL DIAMETER

Valve: 27mm Spout: 30mm

WASTE

with Pop-up Waste

HOLES

3 Hole

MOUNTING

Deck Mounted

PLUMBING SYSTEM SUITABILITY

Gravity System, Pumped System, Combination Boiler, Pressurised System

TECHNICAL DRAWING

COLLECTION: ELEMENTS
PRODUCT CODE: ELW-101F-C/P

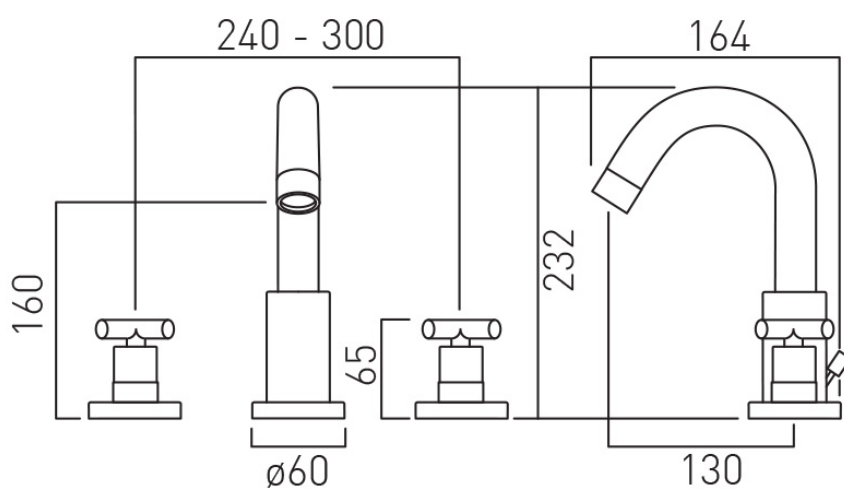

tel: 01934 744466
email: sales@vado.com
www.vado.com

WHERE INSPIRATION FLOWS
TAPS | SHOWERS | ACCESSORIES

